



#Neverstopplaying  
#Neverstoplearning



# The school that I want

By listening to what the school you imagine is like,  
we can offer you the furniture you need.

A school with comfortable, versatile furniture that supports  
the different educational dynamics that take place in it and  
that absorbs the use and pace of the students. Beautiful, solid  
and mobile furniture aligned with today's pedagogies.

We are your partner in furniture to create the school you want.

---

En écoutant à quoi ressemble l'école que vous imaginez, nous  
pouvons vous proposer le mobilier dont vous avez besoin.

Une école au mobilier confortable et polyvalent qui soutient  
les différentes dynamiques pédagogiques qui s'y déroulent et  
qui absorbe l'usage et le rythme des élèves. De beaux meubles  
solides et mobiles alignés avec les pédagogies d'aujourd'hui.

Nous sommes votre partenaire en mobilier  
pour créer l'école que vous souhaitez.

# Who are we?

We are a team with a family tradition and an international spirit that helps schools, high schools and universities around the world to improve their learning spaces.

Providing solutions that create versatile spaces, in which the student is the centre and learning expands, is what drives us.

Nous sommes une équipe avec une tradition familiale et un esprit international qui aide les écoles, lycées et universités du monde entier à améliorer leurs espaces d'apprentissage.

Fournir des solutions qui créent des espaces polyvalents, dans lesquels l'étudiant est le centre et l'apprentissage se développe, est ce qui nous motive.





CLASSROOM DESIGN  
CONCEPTION DE SALLES DE CLASSE



FAST DELIVERY  
LIVRAISON RAPIDE



AFFORDABLE PRICES  
PRIX ABORDABLES



INNOVATIVE PROPOSALS  
PROPOSITIONS INNOVANTES



QUALITY MATERIALS  
MATÉRIAUX DE QUALITÉ



CERTIFICATIONS  
CERTIFICATS



PERSONALIZED ATTENTION  
ATTENTION PERSONNALISÉE





# Colour for learning

The new line of furniture for learning features a colour palette inspired by nature. Colours of the sea, land and sky harmonize the design and offer a calm and comfortable beauty that responds to an expanding trend in the school sector.

La nouvelle ligne de mobilier d'apprentissage propose une palette de couleurs inspirée de la nature. Les couleurs de la mer, de la terre et du ciel harmonisent le design et offrent une beauté calme et confortable qui répond à une tendance croissante dans le secteur scolaire.

**LIGHT  
GREY**

A neutral and balanced colour. Light grey is associated with conservative and sophisticated meanings.

Une couleur neutre et équilibrée. Le gris clair est associé à des significations conservatrices et sophistiquées.

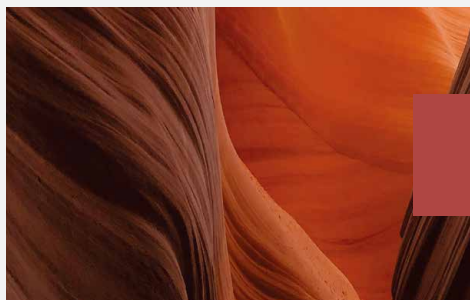

**TERRACOTA**

It's not a single colour, but a family of colours that resemble fired clay. It means "fired earth" and the component colours are typically orange and brown.

Ce n'est pas une seule couleur, mais une famille de couleurs qui ressemblent à de l'argile cuite et les couleurs des composants sont généralement orange et marron.

**OCRE**

Possibly one of the oldest colours and a symbol of life. Some societies quite often associate it with life.

Peut-être l'une des couleurs les plus anciennes et un symbole vital. Certaines sociétés l'associent assez souvent à la vie.



**MINT**

A freshening and welcoming hue associated with summer and water activities because of its similarity to sea shades and pools. It represents tranquillity, balance and calm.

Une teinte rafraîchissante et accueillante associée aux activités estivales et nautiques en raison de sa similitude avec mer et les piscines. Il représente la tranquillité, l'équilibre et le calme.

**NAVY**

Chromatic harmony is the equilibrium that one obtains when the right colours are combined. It is consonance, it is calm, it is a piano perfectly in tune.

L'harmonie chromatique est l'équilibre que l'on obtient lorsque les bonnes couleurs sont combinées. C'est consonance, c'est calme, c'est un piano parfaitement accordé.



**CHARCOAL**

It has a great expressive value: highlights the forms, making them more elegant and sophisticated. It's the colour that combines in perfect harmony with all the others.

La couleur noire a une grande valeur expressive, elle met en valeur les formes, les rendant plus élégantes et sophistiquées, c'est la couleur qui se combine en parfaite harmonie avec toutes les autres.

# Index

Learning  
spaces

10

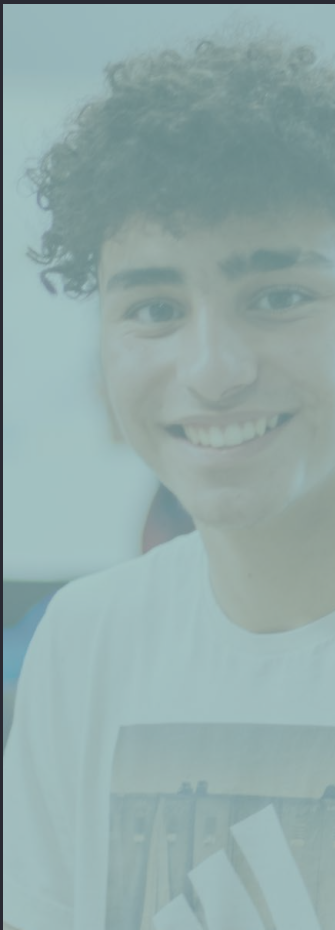

S.T.E.A.M.

32



Technology

40



Teacher's  
space

48



# Multipurpose spaces

56

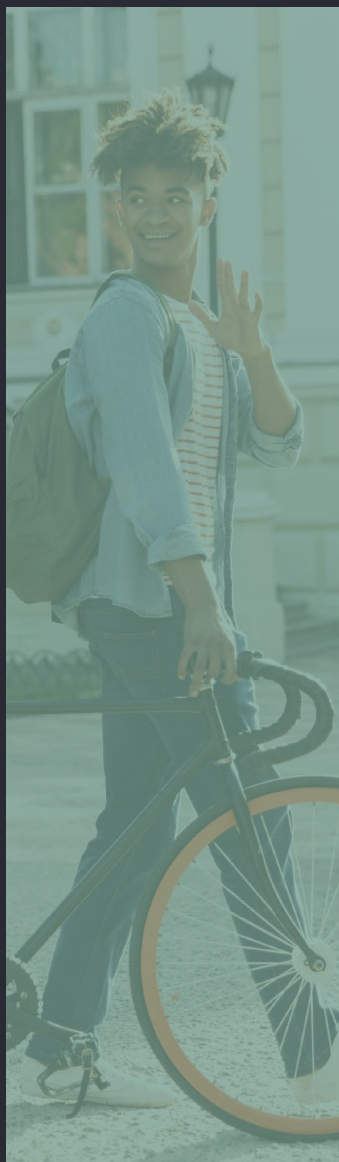

# Canteen

66



# Early ages

74

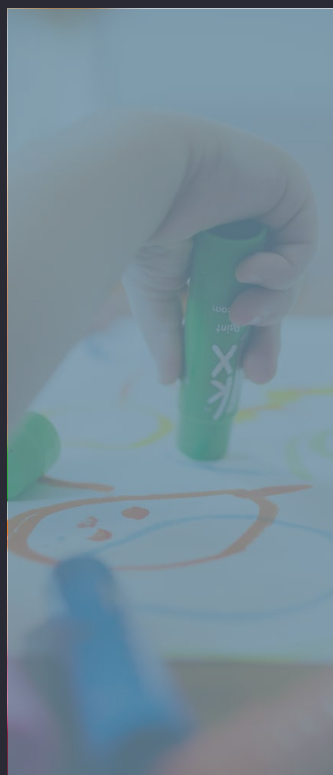

CHAIRS

92



SOFT SEATING

110



TABLES

118



ACOUSTIC

148



CABINETS

156

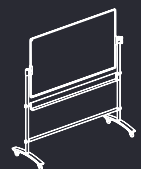

COMPLEMENTS

178



# Learning spaces

Discovering, organizing and transforming our world is exciting, stimulating and a daily challenge we can make a reality in any space.

How can we create diverse learning spaces?

---

Découvrir, organiser et transformer notre monde est passionnant, stimulant et un défi quotidien que nous pouvons réaliser dans n'importe quel espace.

Comment pouvons-nous créer des espaces d'apprentissage diversifiés?



LEARNING SPACES

# The joy of growing and expanding



The school is that friendly and safe space where understanding, creativity and feelings allow to discover both the world and oneself.

L'école est cet espace convivial et sûr où la compréhension, la créativité et les sentiments permettent de découvrir à la fois le monde et soi-même.



*Dividing is adding.*







Separating areas within the same space is easy with panels that also provide acoustic comfort. The learning environment has a deep impact on the educational results of all students. Shall we make the most of every square meter?

Séparer des zones dans le même espace est facile avec des panneaux qui apportent également un confort acoustique. L'environnement d'apprentissage a un impact profond sur les résultats éducatifs de tous les élèves. Profitons-nous au maximum de chaque mètre carré ?



54 m<sup>2</sup>



30





#### HEXA

The HEXA table is the paradigm of versatility and storage optimization.

La table HEXA est le paradigme de la polyvalence et de l'optimisation du rangement.



#### SAMOS

SAMOS acoustic panels divide spaces and dampen sound, making communication easier.

Les panneaux acoustiques SAMOS divisent les espaces et atténuent le son, facilitant la communication.



#### MIA LIFT

Ergonomic MIA chairs favour the natural movement of the body. With padded seat option for extra comfort.

Les chaises ergonomiques MIA favorisent le mouvement naturel du corps. Avec siège rembourré en option pour plus de confort.



*Learning in motion.*



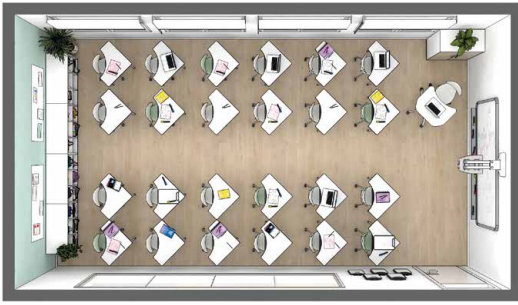

The learning experience needs guidance, but also freedom. Freedom of movement to create and dismantle work groups with versatile tables. Spaces bringing about learning with order and good acoustics to facilitate communication and comfort.

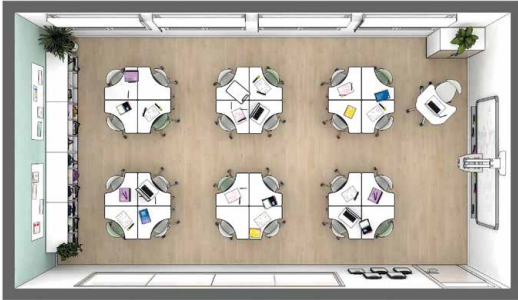

L'expérience d'apprentissage a besoin de conseils, mais aussi de liberté. Liberté de mouvement pour créer et démonter des groupes de travail avec des tables polyvalentes. Des espaces qui favorisent l'apprentissage dans l'ordre et une bonne acoustique pour faciliter la communication et le confort.



45 m<sup>2</sup>



24





The MINI LILY individual whiteboard and its storage system promote order and debate in the classroom.

Le tableau blanc individuel MINI LILY et son système de rangement favorisent l'ordre et le débat en classe.

MINI LILY



The MOON table, adjustable in height, provides teachers with the position within the group that they need at all times.

La table MOON réglable en hauteur offre à l'enseignant la position au sein du groupe dont il a besoin à tout moment..

MOON







*Small changes,  
big improvements.*

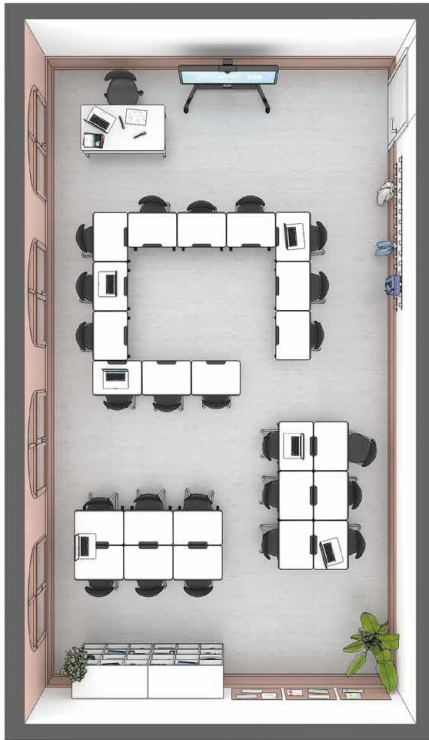

Sometimes, it all comes down to having the ideal chairs and desks to improve concentration, order and comfort, and just letting space and natural light do the rest.

---

Parfois, tout se résume à avoir les chaises et les bureaux idéaux pour améliorer la concentration, l'ordre et le confort, et laisser l'espace et la lumière naturelle faire le reste.



45 m<sup>2</sup>



24





### RECTANGLE TEACHER

The classical teacher's desk with drawer and modesty panel is called RECTANGLE TEACHER.

Le bureau de l'enseignant classique avec tiroir et panneau de modestie est appelé RECTANGLE TEACHER.



### MIA CANTILEVER

The MIA CANTILEVER chair helps to optimize cleanliness and order in classrooms.

La chaise MIA CANTILEVER aide à optimiser la propreté et l'ordre dans les salles de classe.

*Welcome to the  
superclassroom.*







In multi-purpose spaces with multiple dynamics, the Teaching-how-to-Learn paradigm shift shines. In these areas, the organization of space, time and materials is key to facilitating synergies.

Dans les espaces polyvalents aux dynamiques multiples, le changement de paradigme "Enseigner à Apprendre" brille. Dans ces zones, l'organisation de l'espace, du temps et des matériaux est essentielle pour faciliter les synergies.



150 m<sup>2</sup>



60





### MIA TABLE

MIA TABLE chairs with folding table and lower storage tray to easily form and dismantle groups.

Des chaises MIA TABLE avec table pliante et plateau de rangement inférieur pour former et démonter facilement des groupes.



### MIA STORE

Large work tables and MIA STORE chairs with a storage tray so that dynamism in the super classroom does not mean clutter.

Grandes tables de travail et chaises MIA STORE avec un plateau de rangement pour que le dynamisme dans la super salle de classe ne signifie pas l'encombrement.

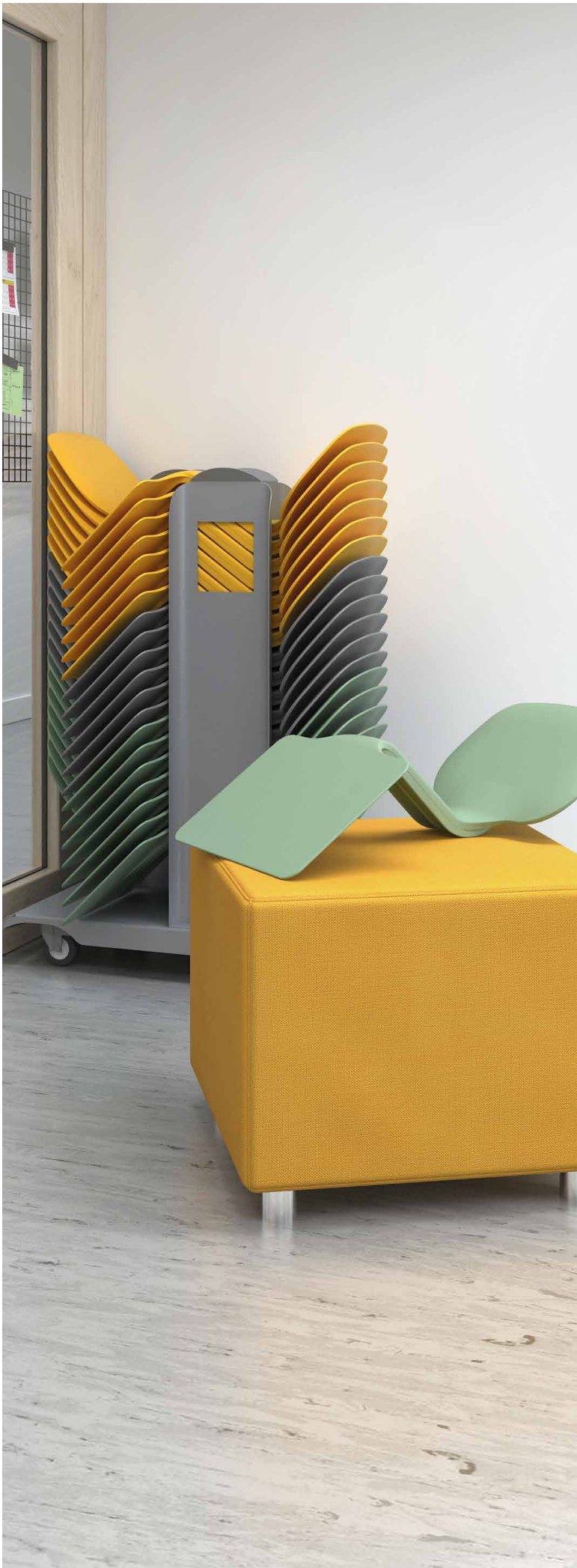

## Marga Tubau

Sales Manager

What can make  
neurons dance?

A strategically placed sofa.  
A panel that turns into a  
mobile whiteboard. Let the  
desire to learn, share ideas  
and contrast them find  
their space in any corner.

Qu'est-ce qui peut faire  
danser les neurones ?

Un canapé stratégiquement  
placé. Un panneau qui  
devient un tableau blanc  
mobile. Faisons en sorte  
que le désir d'apprendre, de  
partager des idées et de les  
confronter trouve sa place  
dans n'importe quel coin.

# Tips for corners



A passage area or a corner of 3m<sup>2</sup> allows a one-on-one meeting.

Une zone de passage ou un coin de 3m<sup>2</sup> permet une rencontre en tête-à-tête.

The combination of grades in different sizes creates a facilitating space for meetings and discussions.

La combinaison de gradins de différentes tailles crée un espace qui facilite les réunions et les discussions.



Create a discussion area in a classroom: it just takes a sofa, a whiteboard and an acoustic divider.

Créer un espace de discussion dans une salle de classe : il suffit d'un canapé, d'un tableau blanc et d'un séparateur acoustique.

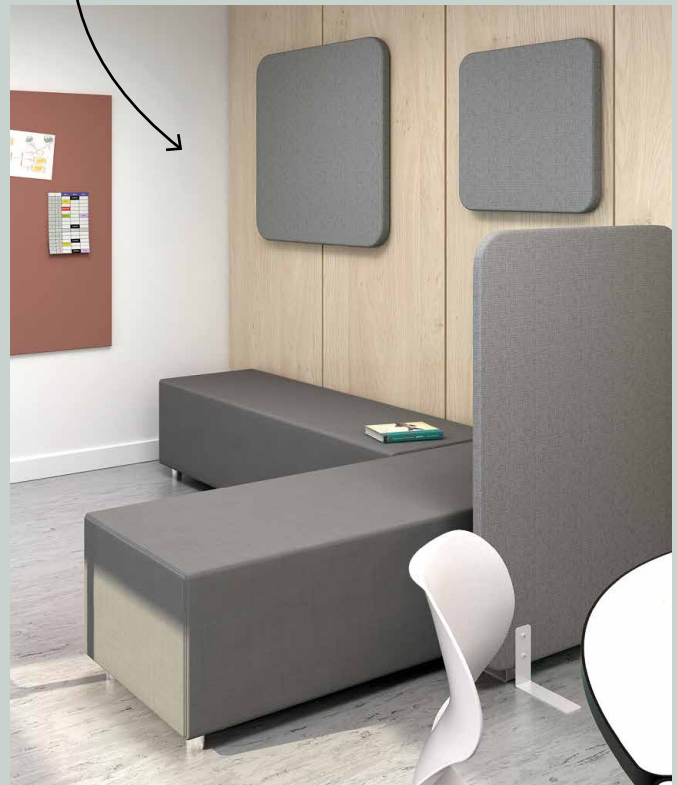



Handwritten notes in blue ink, partially obscured by a large, semi-transparent orange circle. The text is mirrored and appears to be bleed-through from the reverse side of the page.

Handwritten notes in blue ink, partially obscured by a large, semi-transparent orange circle. The text is mirrored and appears to be bleed-through from the reverse side of the page.

Handwritten notes in blue ink, partially obscured by a large, semi-transparent orange circle. The text is mirrored and appears to be bleed-through from the reverse side of the page.

Handwritten notes in blue ink, partially obscured by a large, semi-transparent orange circle. The text is mirrored and appears to be bleed-through from the reverse side of the page.

Handwritten notes in blue ink, partially obscured by a large, semi-transparent orange circle. The text is mirrored and appears to be bleed-through from the reverse side of the page.



# S.T.E.A.M.

*Science. Technology.  
Engineering. [Arts]. Maths.*

Transversal and multidisciplinary learning enhances the capacity for research, exploration, problem solving and curiosity. Learn by combining various fields of knowledge in the same space.

How to create STEAM learning classrooms?

---

L'apprentissage transversal et multidisciplinaire renforce la capacité de recherche, d'exploration, de résolution de problèmes et de curiosité.

Apprendre en combinant divers domaines de connaissances dans un même espace.

Comment créer des salles de classe d'apprentissage STEAM ?



S.T.E.A.M.

# Classrooms with space for everything

The desire to learn is the engine for knowledge and an endless source of personal satisfaction. Stimulating spaces have to be created.

A classroom where the teacher can play different roles and students can perform different activities at the same time?

Le désir d'apprendre est le moteur de la connaissance et une source infinie de satisfaction personnelle. Il faut créer des espaces stimulants.

Une salle de classe où l'enseignant peut jouer différents rôles et où les élèves peuvent effectuer différentes activités en même temps ?

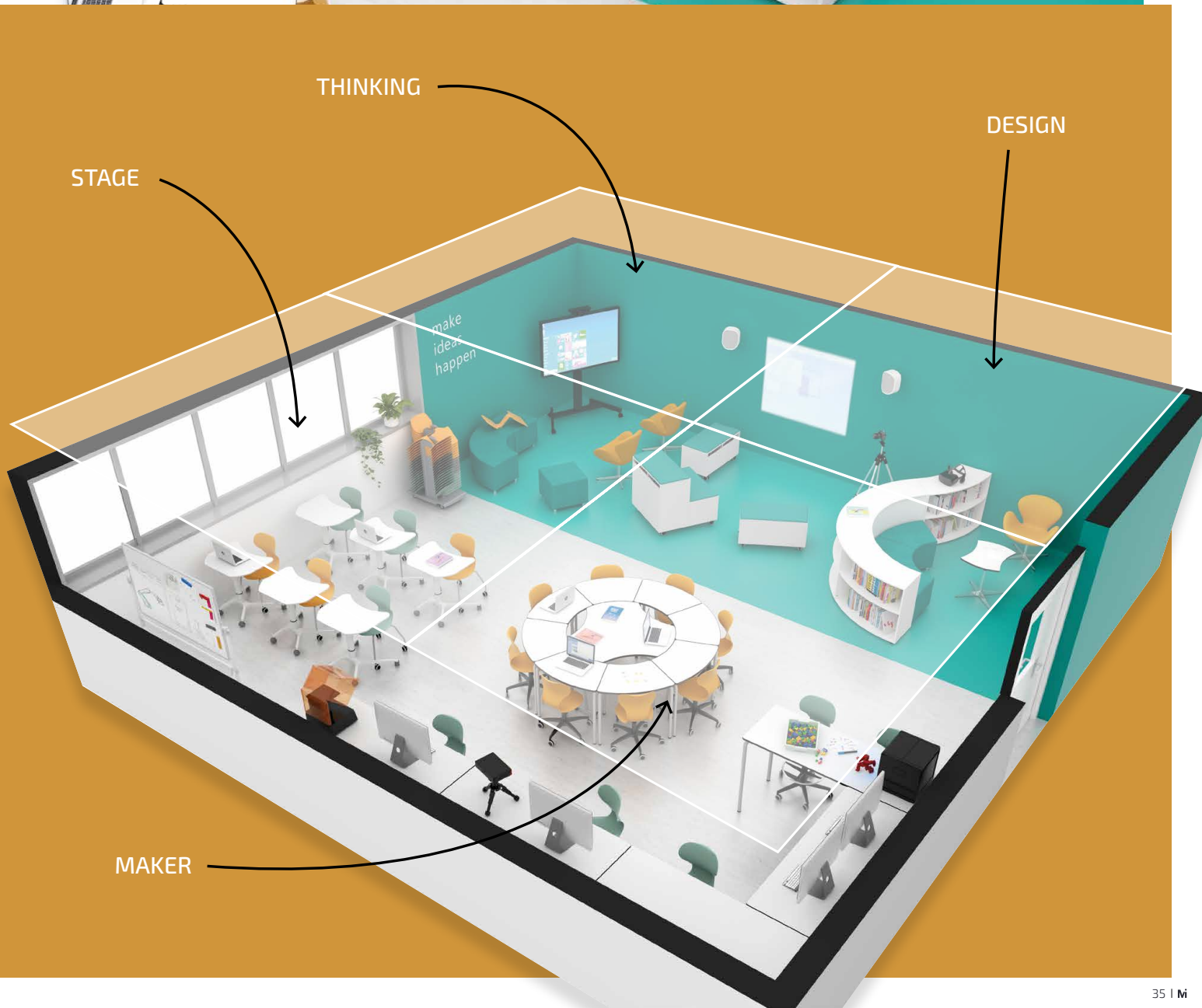

*The same stage  
multiple spaces*



make  
ideas  
happen



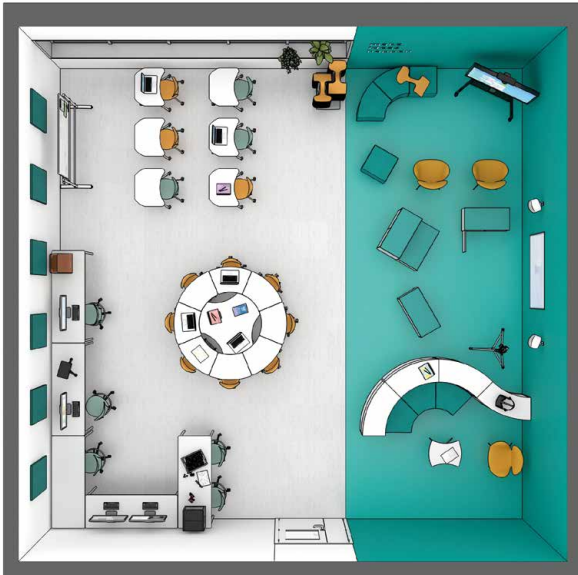

A multidirectional space with zones to carry out different activities related to the same project not only optimizes time and space, but it also fosters concentration and cooperative work.

The goal is to create spaces that are allied with knowledge. Shall we do it?

Un espace multidirectionnel avec des zones pour réaliser différentes activités liées au même projet optimise non seulement le temps et l'espace, mais il favorise également la concentration et le travail en coopération.

L'objectif est de créer des espaces alliés au savoir. - On y va ?



87 m<sup>2</sup>



40





MOVE

MINI MOVE

MOVE and MINI MOVE grades create a forum area for exhibitions and debates.

Les gradins MOVE et MINI MOVE créent un espace de forum pour les expositions et les débats.



OCTA

TRISIX

OCTA and TRISIX tables allow you to quickly create work groups, providing a design zone when needed.

Les tables OCTA et TRISIX vous permettent de créer rapidement des groupes de travail, offrant une zone de conception en cas de besoin.



# Tech —nology

The technological ecosystem is part of the life of 21st century students. They are protagonists and will be the creators of the technology we use on a daily basis. Programming, ICT and robotics have their own space.

How to foster technological learning?

---

L'écosystème technologique fait partie de la vie des étudiants du 21e siècle. Ils sont les protagonistes et seront les créateurs de la technologie que nous utilisons au quotidien. La programmation, les TIC et la robotique ont leur propre espace.

Comment faciliter l'apprentissage technologique ?

TECHNOLOGY

# Technology is the way, not the message.

By programming, students improve their ICT knowledge and they also learn to work in groups, negotiate, be assertive, manage frustration, present ideas, gain efficiency, security, analytical skills and a large number of necessary abilities in the current and future work environment.

---

Grâce à la programmation, les étudiants améliorent leurs connaissances en TIC et ils apprennent également à travailler en groupes, à négocier, à être assertifs, à gérer la frustration, à présenter des idées, à gagner en efficacité, en sécurité, en compétences analytiques et en un grand nombre de compétences nécessaires dans l'environnement de travail actuel et futur.





### Periodic Table of Elements

Periodic Table of Elements																																																																																																																					
Metals										Nonmetals																																																																																																											
Alkali Metals										Alkaline Earth Metals		Transition Metals		Other Metals		Metalloids		Noble Gases		Lanthanoids		Actinoids																																																																																															
H He Li Be B C N O F Ne Na Mg Al Si P S Cl Ar K Ca Sc Ti V Cr Mn Fe Co Ni Cu Zn Ga Ge As Se Br Kr Rb Sr Y Zr Nb Mo Tc Ru Rh Pd Ag Cd In Sn Sb Te Xe Ba La Ce Pr Nd Pm Sm Eu Gd Tb Dy Ho Er Tm Yb Lu Hf Ta W Re Os Ir Pt Au Hg Tl Pb Bi Po At Rn Ac Th Pa U Np Pu Am Cm Bk Cf Es Fm Md No Lr																																																																																																																					
1	2	3	4	5	6	7	8	9	10	11	12	13	14	15	16	17	18	19	20	21	22	23	24	25	26	27	28	29	30	31	32	33	34	35	36	37	38	39	40	41	42	43	44	45	46	47	48	49	50	51	52	53	54	55	56	57	58	59	60	61	62	63	64	65	66	67	68	69	70	71	72	73	74	75	76	77	78	79	80	81	82	83	84	85	86	87	88	89	90	91	92	93	94	95	96	97	98	99	100	101	102	103	104	105	106	107	108	109	110	111	112	113	114	115	116	117	118

# *Ideas lab.*





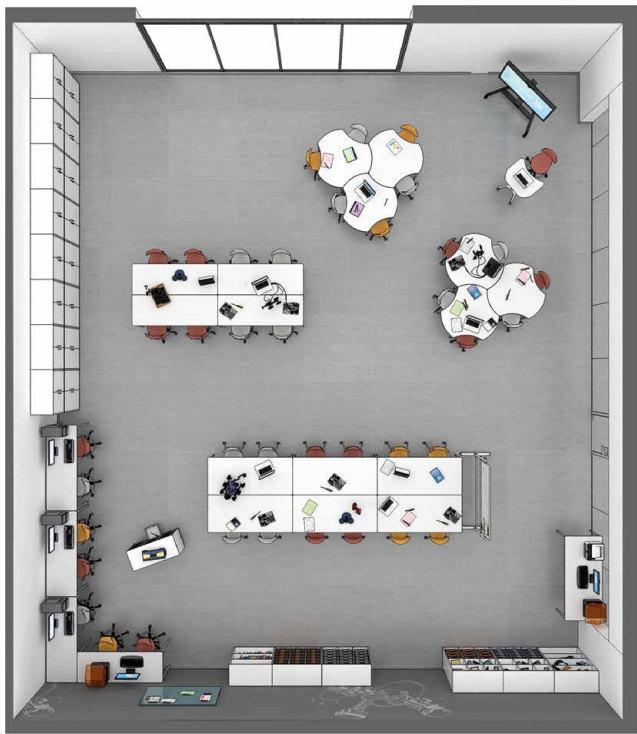

Design contributes to making the educational experience more effective, pleasant and fulfilling in the technology classroom.

Freedom of movement is key here for an agile manipulation of the object of study and the possibility of grouping in small work teams. Whiteboards and mobile auxiliary furniture allow the sharing of ideas and materials

La conception contribue à rendre l'expérience éducative plus efficace, agréable et enrichissante dans la salle de classe technologique.

Ici la liberté de mouvement est essentielle pour une manipulation agile de l'objet d'étude et la possibilité de se regrouper en petites équipes de travail. Les tableaux blancs et le mobilier auxiliaire mobile permettent le partage d'idées et de matériaux.



150 m<sup>2</sup>



45





MIA STOOL

RECTANGLE PLUS

High and spacious tables, ideal for teamwork and ergonomic stools.  
RECTANGLE PLUS table and MIA stools.

Tables hautes et spacieuses, idéales pour le travail d'équipe et tabourets ergonomiques.  
Table RECTANGLE et tabourets MIA.



TRISIX

Versatile and easy to fit tables to form and dismantle work teams.

Des tables polyvalentes et faciles à installer pour créer et démanteler des équipes de travail.

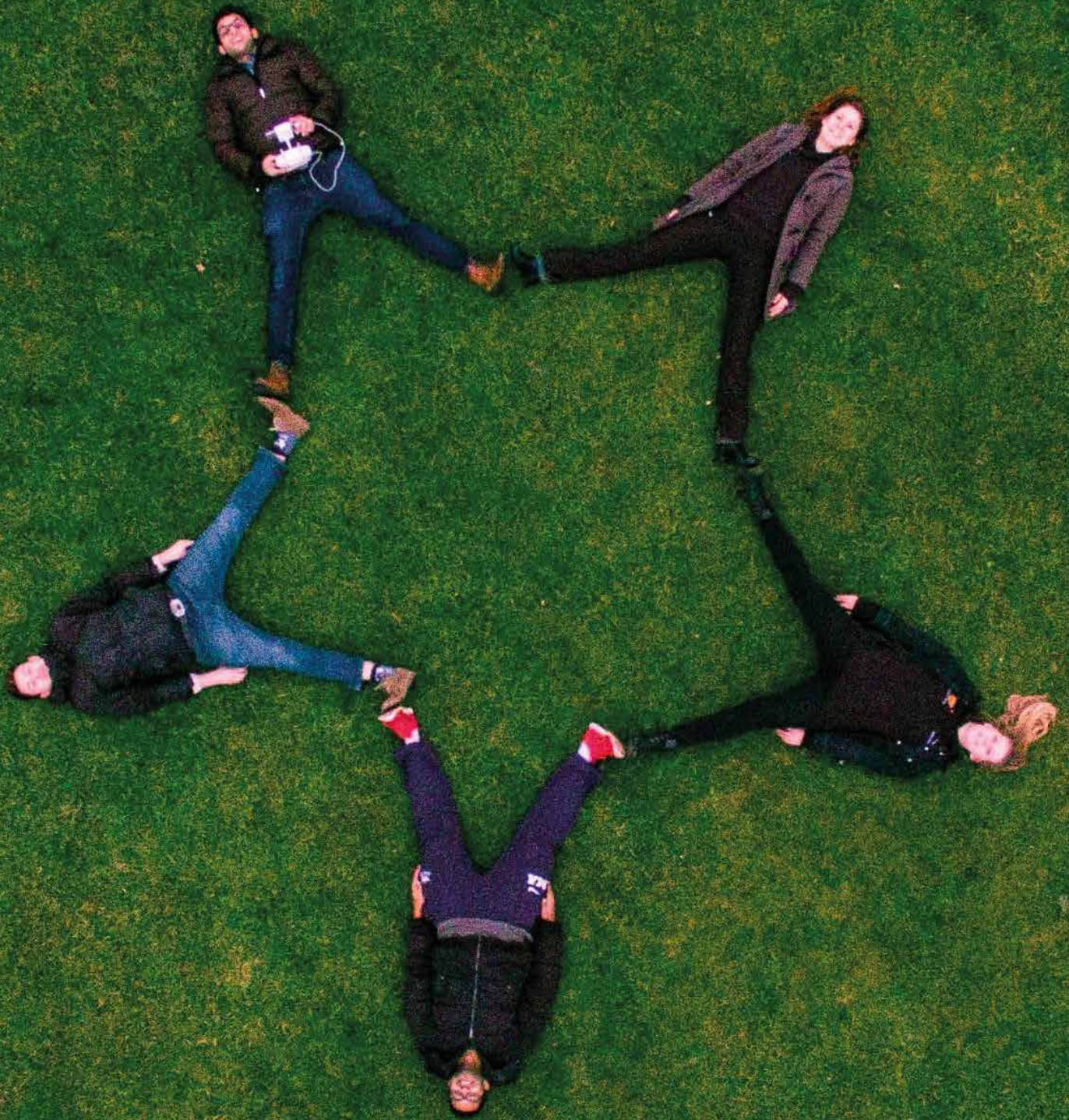

# Teacher's space

The engine and heart of the school are the teaching team. Teachers need a space to rest, relax and at the same time work as a team, talk and continue promoting education today and tomorrow.

How do you imagine the staff room?

---

Le moteur et le cœur de l'école, c'est l'équipe pédagogique. Les enseignants ont besoin d'un espace pour se reposer, se détendre et en même temps travailler en équipe, discuter et continuer à promouvoir l'éducation d'aujourd'hui et de demain.

Comment imaginez-vous la salle des professeurs ?

TEACHER'S SPACE

# Creators of learning experiences

If the teacher is the designer of the learning experience, the educational space is the setting that inspires it.

---

Si l'enseignant est le concepteur de l'expérience d'apprentissage, l'espace éducatif est le cadre qui l'inspire.

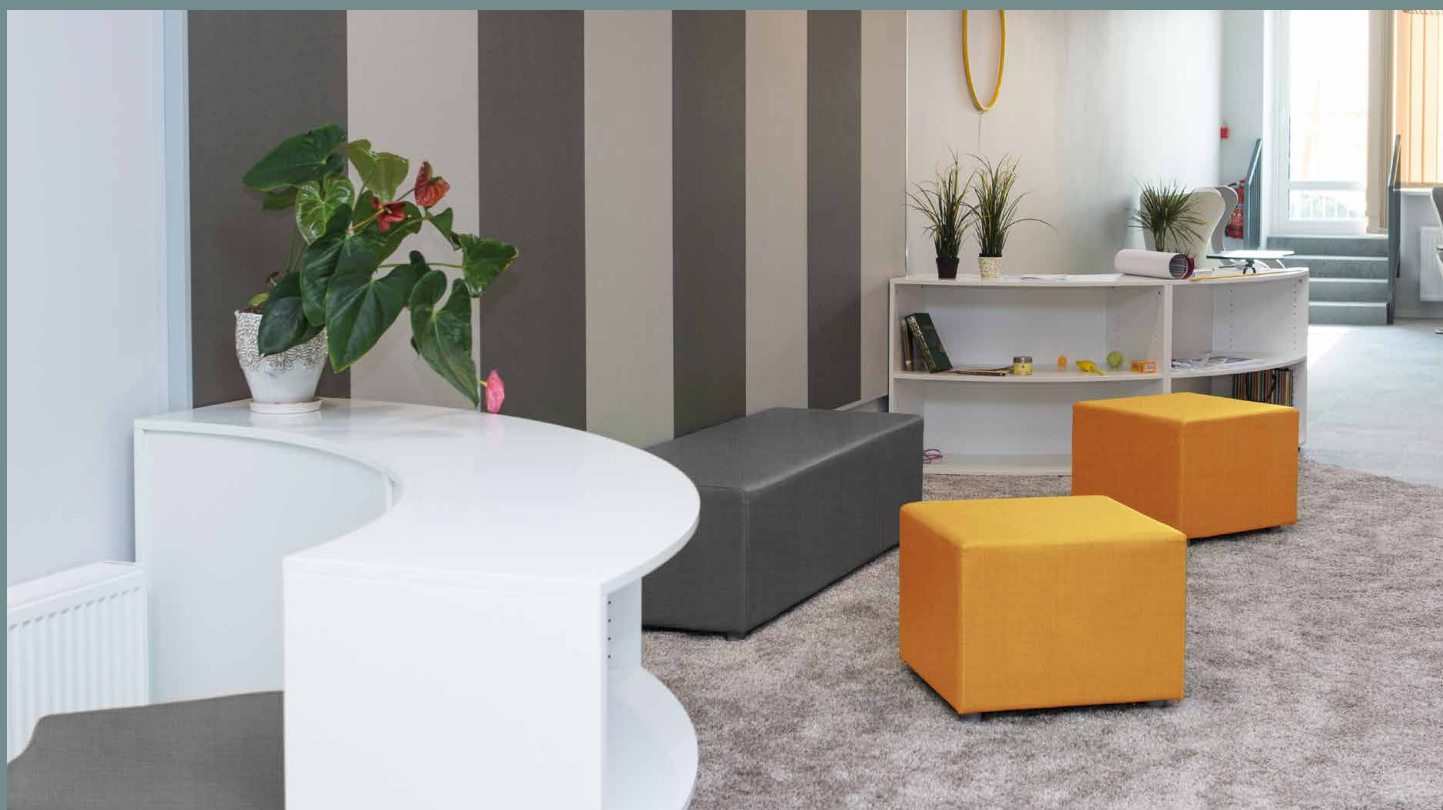



*A small oasis.*





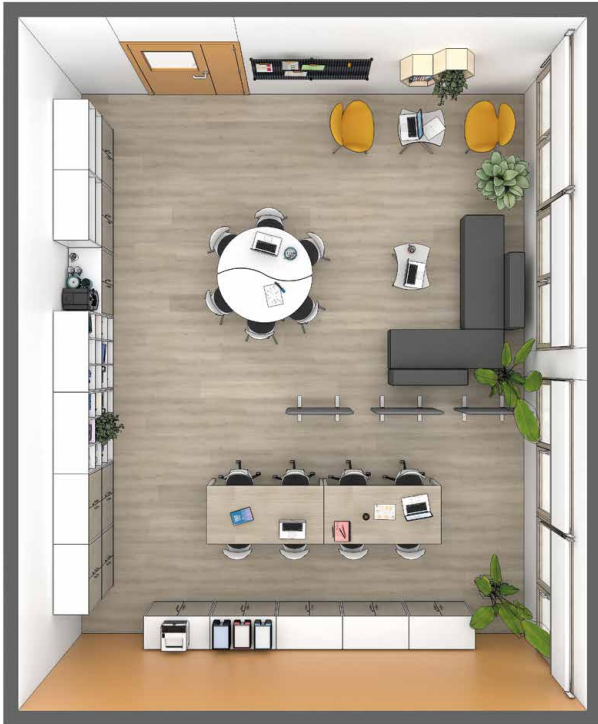

The place for reflection, assessment, content preparation and rest. The space for interaction between co-workers and meetings between tutors and students.

Le lieu de réflexion, d'évaluation, de préparation du contenu et de repos. L'espace d'interaction entre collègues et de rencontres entre tuteurs et étudiants.



50 m<sup>2</sup>



22





### SAMOS

SAMOS dividers separate and isolate acoustically.

Les panneaux SAMOS séparent et isolent acoustiquement.

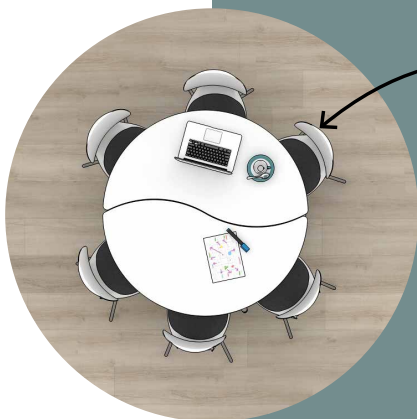

### YANG

YANG tables to close the circle.

Table YANG pour fermer le cercle



The background of the page features a photograph of a bicycle wheel with a bright orange rim and white spokes, positioned in the lower-left corner. The rest of the background is a blurred view of a light-colored building facade with windows and architectural details.

# Multi — purpose spaces

Spaces are constantly evolving and many of them are transformed and inhabited in multiple ways. The diversity of activities gives way to the versatility, movement and multiple uses of furniture.

How to create multifunctional spaces?

---

Les espaces sont en constante évolution et bon nombre d'entre eux sont transformés et habités de multiples façons. La diversité des activités laisse la place à la versatilité, au mouvement et aux multiples usages du mobilier.

Comment créer des espaces multifonctionnels ?

## MULTIPURPOSE SPACES

# Libraries shout: **Come!**

Libraries go from being a place where people just do research to become a place to go to feel more productive or to be close to friends and colleagues.

They become interdisciplinary, inclusive and inspiring learning spaces.

Les bibliothèques passent de l'état d'endroit où les gens font simplement de la recherche à un endroit où aller pour se sentir plus productifs ou pour être proches d'amis et de collègues. Ils deviennent des espaces d'apprentissage interdisciplinaires, inclusifs et inspirants.





*Wellness feeling.*





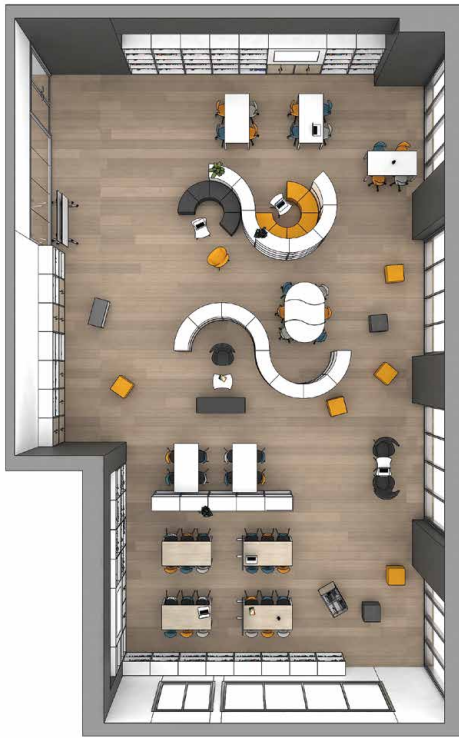

Libraries are at the intersection of academic, social and emotional needs. They become a meeting place where students can grow in many aspects.

Les bibliothèques sont à l'intersection des besoins académiques, sociaux et émotionnels. Ils deviennent un lieu de rencontre où les étudiants peuvent progresser dans de nombreux domaines.



220 m<sup>2</sup>



75





Areas to sit and read as you would at home. Set of armchair and low table.

CHARLOTTE

Des espaces pour s'asseoir et lire comme à la maison. Ensemble de fauteuil et table basse.

LOUISE



Furniture with organic shapes that allows dividing spaces and create a comfort zone with sofas.

MARIE

Des meubles aux formes organiques qui permettent de diviser les espaces et de créer une zone de confort avec des canapés.





## Joan Jalencas

Sales Manager

Get together, meet, concentrate, explain, experiment, share, listen actively, etc., in different areas within the same educational, with versatile and mobile furniture, as well equipped as the mind is when learning.

Se réunir, se rencontrer, se concentrer, s'expliquer, expérimenter, partager, écouter activement, etc., dans différents domaines dans un même espace pédagogique, avec des meubles polyvalents et mobiles, aussi bien équipés que l'esprit lorsqu'il apprend.

# Tips for corners



The MARIE curved cabinet surrounds an space that, together with the ANGLE sofa, invites to meet in small groups to debate.

L'armoire courbe MARIE entoure un espace qui, avec le canapé ANGLE, invite à se réunir en petits groupes pour débattre.

The double-height MARIE curved cabinet creates an interior space that enables a quiet work area with a large table.

L'armoire courbe MARIE en double hauteur crée un espace intérieur qui permet un espace de travail au calme avec une grande table.



The CHARLOTTE armchair, with its wraparound seat, leads to internalisation, calm and meditation.

Le fauteuil CHARLOTTE, avec son assise enveloppante, invite à l'intériorisation, au calme et à la méditation.







# Canteen

Educate, socialize and rest in the canteen  
to nurture students and teachers.

Each age has specific needs and creating a pleasant and  
calm atmosphere around the table is the starting point.

How to create canteens that nurture learning?

---

Éduquer, socialiser et se reposer à la cantine  
pour nourrir les élèves et les enseignants.

Chaque âge a des besoins spécifiques et créer  
une atmosphère agréable et calme autour  
de la table est le point de départ.

Comment créer des cantines qui nourrissent l'apprentissage ?

CANTEEN

# Much more than eating

Eating is a basic need. So are socializing, enjoying, savouring, learning, sharing, relaxing and nourishing oneself internally and externally.

---

Manger est un besoin fondamental. Comme socialiser, profiter, savourer, apprendre, partager, se détendre et se nourrir à l'intérieur et à l'extérieur.





# Meeting point.







As at home, where kitchen becomes the nerve centre where life happens, we can turn the canteen into something more than just a place to eat. The wood finishes, the organic colors and the design aiming to offer comfort are the key.

Comme à la maison, où la cuisine devient le centre névralgique où la vie se déroule, nous pouvons transformer la cantine en quelque chose de plus qu'un simple endroit pour manger. Les finitions en bois, les couleurs organiques et le design visant à offrir du confort sont la clé.



108 m<sup>2</sup>



48





### LUCA

The LUCA chair is stackable, easy to clean and maintain.

La chaise LUCA est empilable, facile à nettoyer et à maintenir.



### IRENE

The IRENE cabinet with its wooden doors brings warmth to the canteen and helps keep the space tidy and clean.

L'armoire IRENE avec ses portes en bois apporte de la chaleur à la cantine et aide à garder l'espace bien rangé et propre.





# Early ages

Feeling safe playing, experimenting calmly, surrounded by beauty and order. Spaces where the little ones are the protagonists offer comfort and security to imagine, create and grow freely.

How to create learning spaces that promote calm?

---

Se sentir en sécurité en jouant, en expérimentant calmement, entouré de beauté et d'ordre. Les espaces où les plus petits sont les protagonistes offrent confort et sécurité pour imaginer, créer et grandir librement.

Comment créer des espaces d'apprentissage qui favorisent le calme ?

EARLY AGES

# Sensory experimentation

A classroom with different corners where symbolic play can be developed and sensory stimulation favored by manipulating different objects that are the center of interest for the little ones.

Une salle de classe avec différents coins où le jeu symbolique peut être développé et la stimulation sensorielle favorisée par la manipulation de différents objets qui sont le centre d'intérêt des plus petits.





# *The living classroom.*





$2+2=4$   
 $3-5=2$   
123

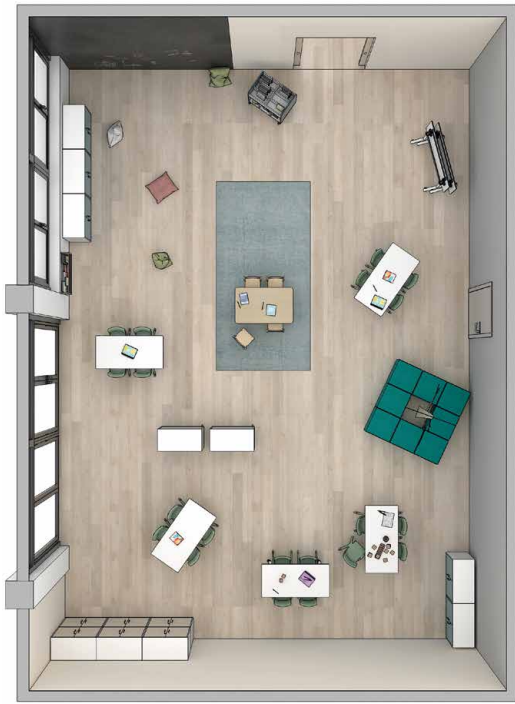

Classrooms where different educational dynamics coexist simultaneously, where the little ones move, group and ungroup to experiment, rest, play.

Des salles de classe où différentes dynamiques pédagogiques coexistent simultanément, où les plus petits bougent, se regroupent et se dégroupent pour expérimenter, se reposer, jouer.



100 m<sup>2</sup>



25





TEO

The wood in tables (TEO) and chairs (ZOE) brings warmth and comfort to the classroom.

Le bois des tables (TEO) et des chaises (ZOE) apporte chaleur et confort à la classe.

ZOE



HEDY

The HEDY cabinet on castors allows you to comfortably and dynamically separate spaces.

L'armoire à roulettes HEDY permet de séparer confortablement et dynamiquement les espaces.

MINIFLOOP

The MINIFLOOP tables are folding and allow you to quickly transform a workspace into an open space to play or rest.

Les tables MINIFLOOP sont pliantes et permettent de transformer rapidement un espace de travail en espace ouvert pour jouer ou se reposer.



*Montessori-inspired  
classroom.*





A modular classroom in which cooperative work is the core and the child the protagonist of their experience and learning. With tables that allow various configurations to expand the multiple intelligences.

Une salle de classe modulaire dans laquelle le travail coopératif est l'axe du projet et l'enfant le protagoniste de son expérience et de son apprentissage. Avec des tables qui permettent diverses configurations pour étendre les multiples intelligences.



40 m<sup>2</sup>



25





MIA MINILIFT

The MIA MINILIFT chair for adults adapts to the height of children's tables for greater comfort for teachers and students.

La chaise MIA MINILIFT pour adultes s'adapte à la hauteur des tables des enfants pour un plus grand confort des professeurs et des élèves.

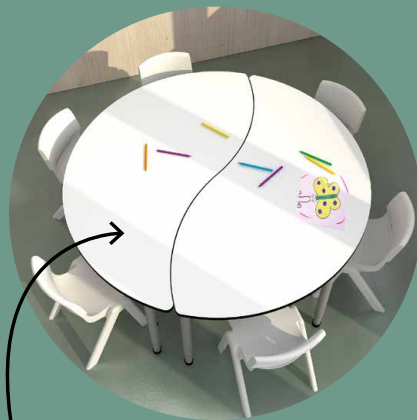

MIA MINILIFT

The YANG table allows you to quickly create round tables and also different configurations.

La table YANG permet de créer rapidement des tables rondes et aussi différentes configurations.



*The importance  
of order.*





Storage in the classroom favors both spatial and mental order. Tables and cabinets that, with their design, colour and resistance to shocks and water, favor visual and experiential harmony in the classroom.

Le rangement dans la salle de classe favorise à la fois l'ordre spatial et mental. Des tables et des armoires qui, par leur design, leur couleur et leur résistance aux chocs et à l'eau, favorisent l'harmonie visuelle et expérimentielle dans la salle de classe.



60 m<sup>2</sup>



25





### GRACE

The GRACE cabinet with trays in two sizes, guided by rails to prevent them from coming out of the cabinet.

L'armoire GRACE avec des bacs en deux tailles, guidés par des rails pour les empêcher de sortir du meuble.



### RONY

The RONY table has adjustable legs at different heights for the comfort of all.

La table RONY a des pieds réglables à différentes hauteurs pour le confort de tous.

# Furnishing spaces that furnish minds

This is our passion. We understand how students learn and how educators in the 21st century want to teach. As education keeps evolving, so do we.

---

C'est notre passion. Nous comprenons comment les élèves apprennent et comment les éducateurs du 21e siècle veulent enseigner. Au fur et à mesure que l'éducation évolue, nous aussi.

**CHAIRS**

CHAISES

92



**SOFT SEATING**

SOFT SEATING

110



**TABLES**

TABLES

118



**ACOUSTIC**

ACOUSTIQUE

148

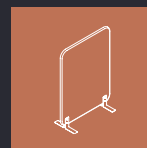

**CABINETS**

ARMOIRE

156



**COMPLEMENTS**

ACCESSOIRES

178



# Chairs

Reconcile with the movement.  
Chairs that facilitate grouping and ungrouping quickly and without noise, that promote order and prioritize dynamic comfort. Chairs not only designed for sitting down.

---

Esta es nuestra pasión. Entendemos cómo aprenden los estudiantes y cómo quieren enseñar los docentes del siglo XXI. A medida que la educación continúe evolucionando, nosotros también.





# JON

Ref. 1045



## SIZE

(+info P. 193)

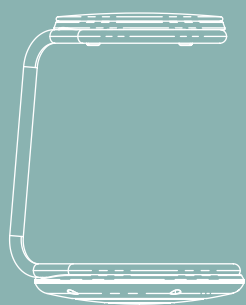

53,5 CM

7

## DETAILS



# JON







# MIA



MIA BASIC



MIA CANTILEVER



MIA CASTORS



MIA MINI LIFT



MIA LIFT



MIA BIG LIFT



MIA STOOL



MIA STORE



MIA TABLE





# MIA BASIC

Ref. 1028



## SIZE (+info P. 193)

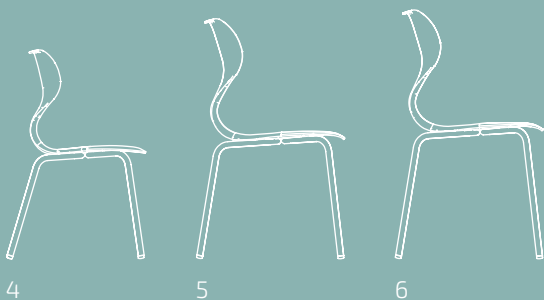

## OPTIONS



## DETAILS



# MIA CANTILEVER

Ref. 1027



## SIZE

(+info P. 193)



5



6

## OPTIONS



## DETAILS





# MIA CASTORS

Ref. 1029



## SIZE

(+info P. 193)



4



5



6

## OPTIONS



## DETAILS



# MIA MINI LIFT

Ref. 169



## SIZE

(+info P. 193)

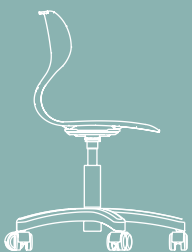

31-41 CM

## DETAILS





# MIA LIFT

Ref. 1035



## SIZE

(+info P. 193)

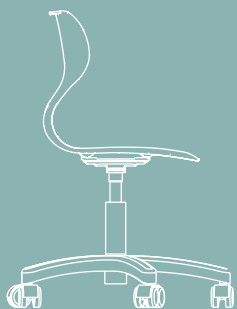

40-51 CM

## OPTIONS



## DETAILS



# MIA BIG LIFT

Ref. 1039



## SIZE

(+info P. 193)

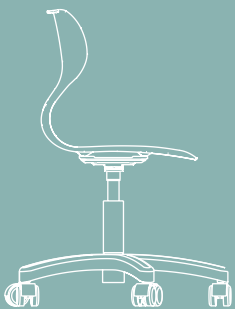

40-51 CM

## OPTIONS





# MIA STOOL

Ref. 1030



## SIZE

(+info P. 193)



58-83 CM

## OPTIONS



## DETAILS



# MIA STORE

Ref. 1038



## SIZE

(+info P. 193)

## OPTIONS

## DETAILS

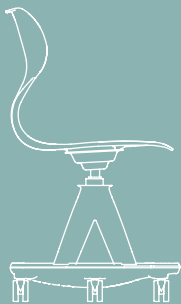

6





# MIA TABLE

Ref. 1036



## SIZE

(+info P. 193)

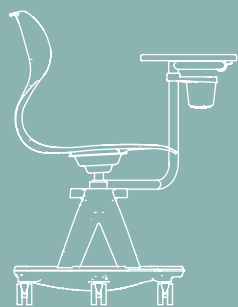

57X33 CM

6

## OPTIONS



## DETAILS





360°



¿Cómo funciona? Mira el vídeo aquí:

How does it work? Watch the video here:





# ZTOOL

Ref. 1020



36X25 CM



# ZTOOL TROLLEY

Ref. 1037



X 40 ZTOOL



YouTube



How does it work? Watch the video here:  
¿Cómo funciona? Mira el vídeo aquí:



SIZE  
(+info P. 193)

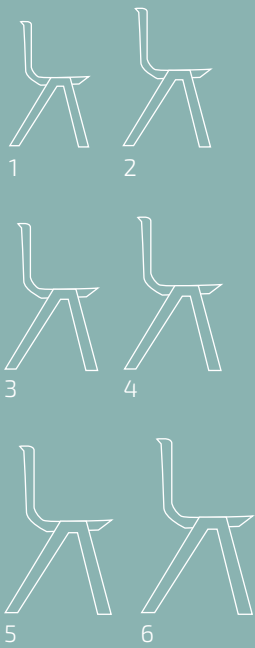

## LUCA

Ref. 167

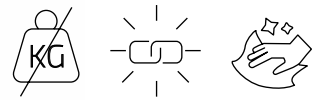

SIZE  
(+info P. 193)

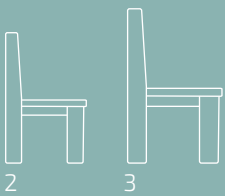

DETAILS | DETALLES



## ZOE

Ref. 1044



# Soft seating

Socializar, compartir y relajarse.  
El mobiliario soft seating permite  
crear un espacio para conversaciones  
improvisadas y permite dar vida  
a zonas del centro educativo  
hasta ahora desaprovechadas.

---

Socialiser, partager et se détendre.  
Le soft seating vous permet  
de créer un espace pour des  
conversations impromptues et  
vous permet de donner vie à des  
zones du centre éducatif qui n'ont  
pas été utilisées jusqu'à présent.







# CHLOE

Ref. CHLOE

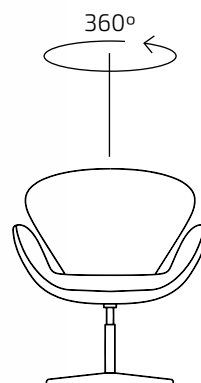

## SIZE

69 CM



67 CM



79 CM

44 CM

## DETAILS



# CHARLOTTE

Ref. 1041

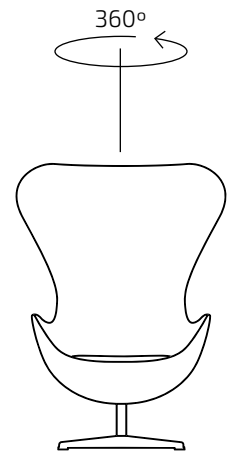

## SIZE

82 CM

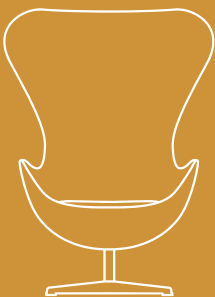

77 CM



108 CM

42 CM

## DETAILS





# ANGLE

Ref. 12001

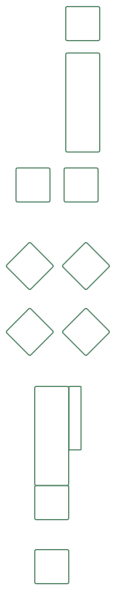
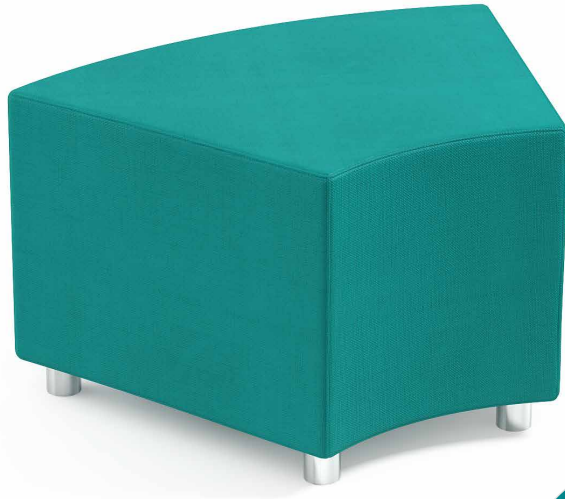

# CUBE

Ref. 12002

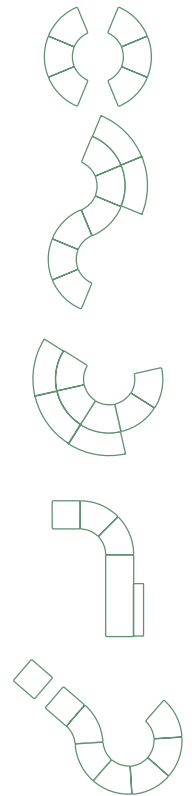

## SIZE

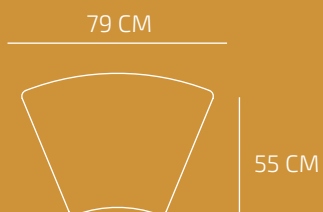

## SIZE

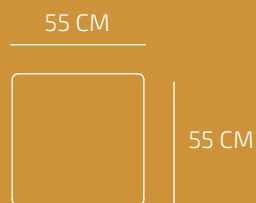

## DETAILS





# TUBE

Ref. 12003

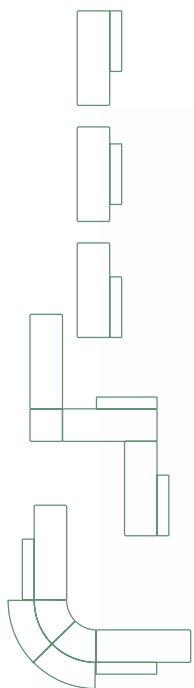
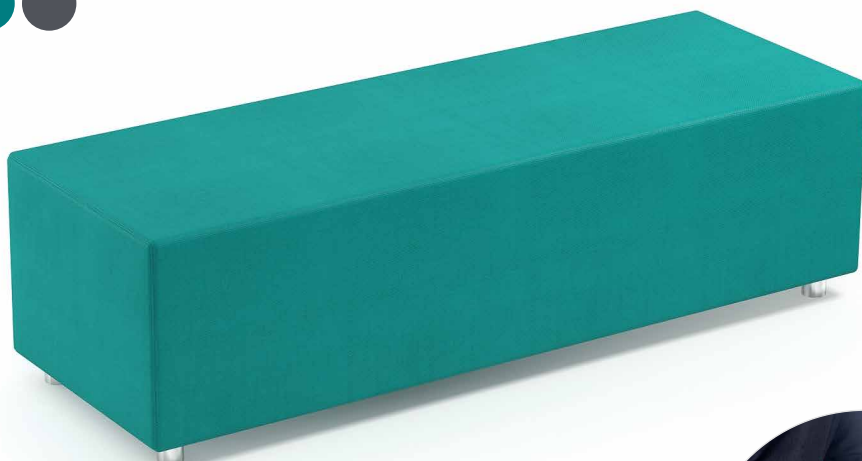

# COMPLETE SOFA

Ref. 12005

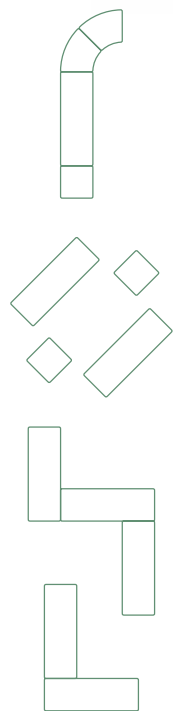

## SIZE

160 CM

55 CM

75 CM

55 CM

## DETAILS





# MOVE

Ref. 1608



Easy to move



## SIZE

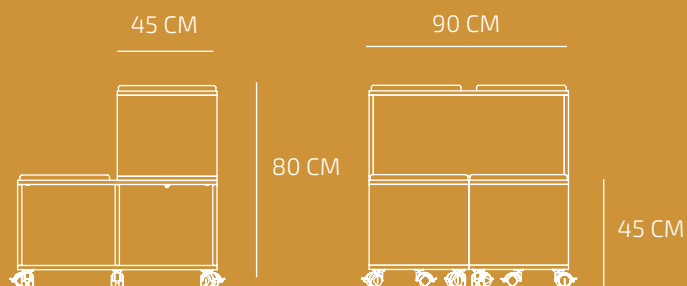

## DETAILS



# MINI MOVE

Ref. 1609



Easy to move



## SIZE

45 CM

90 CM

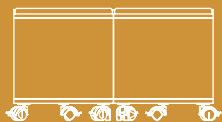
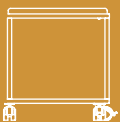

45 CM

## DETAILS



# Tables

Work platforms. Tables that allow classrooms to be quickly configured and adapted for collaborative work. With height-adjustable, mobile, easy to fit and storable designs to quickly facilitate the execution of any task.

---

Plates-formes de travail. Des tables qui permettent de configurer rapidement les salles de classe et de les adapter au travail collaboratif. Avec des conceptions réglables en hauteur, mobiles, encastrables et faciles à ranger pour faciliter rapidement l'exécution de n'importe quelle tâche."





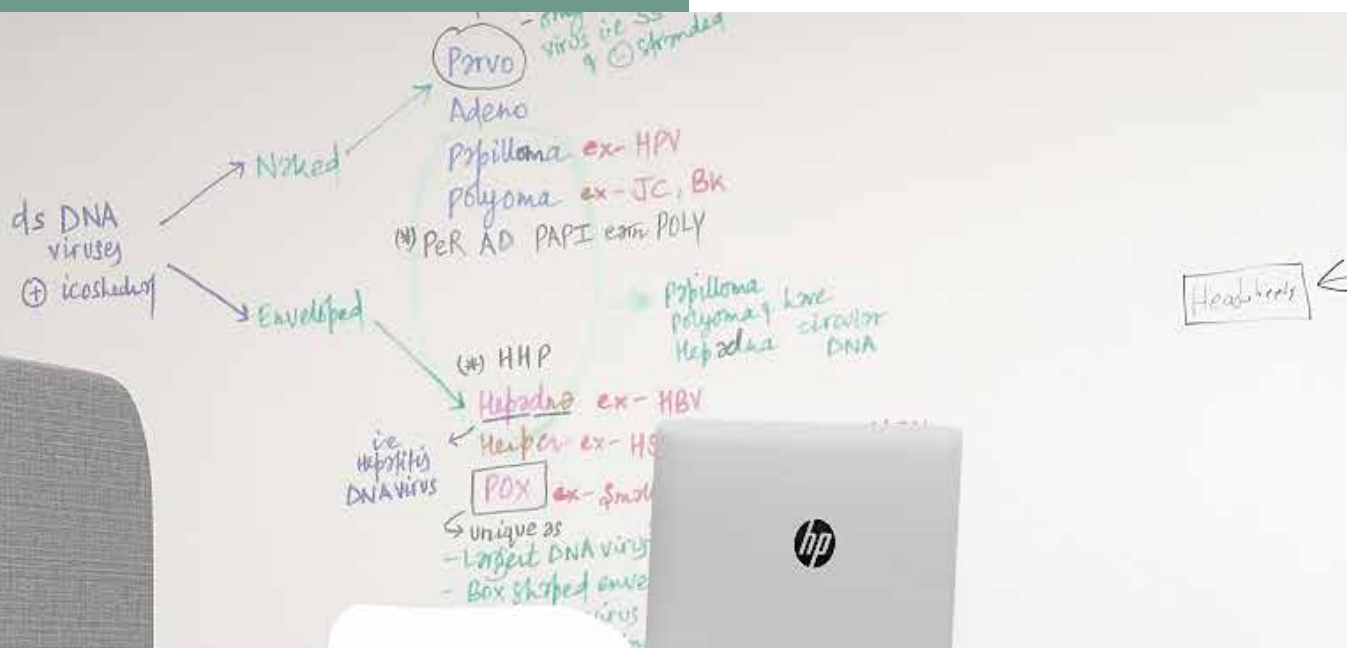

# MOON

Ref. 2362



MAX.  
H 102 cm



MIN.  
H 73 cm



## SIZE

(+info P. 193)

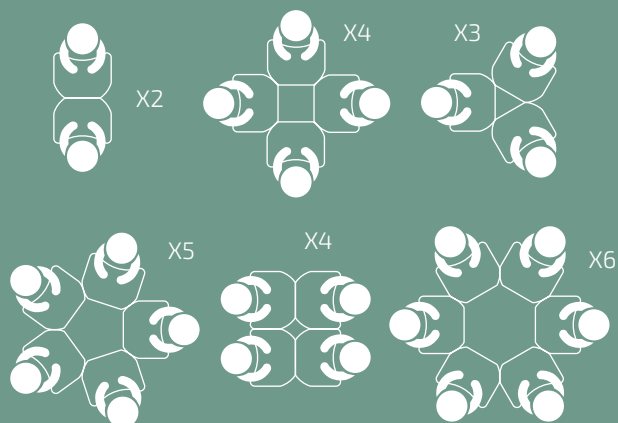

## DETAILS





# SQUARE

Ref. 2341IN



## SIZE

(+info P. 193)

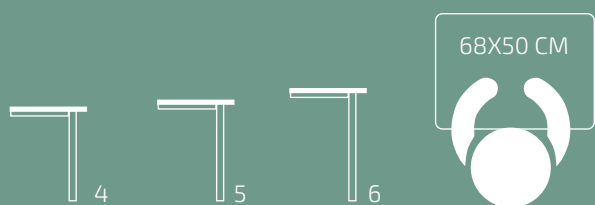

## DISTRIBUTION

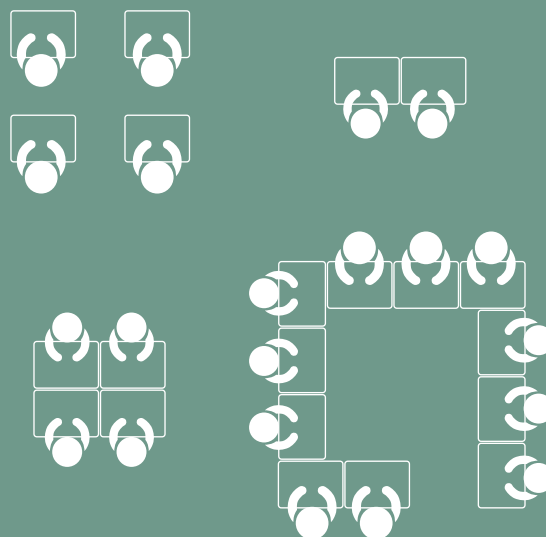

## COMBINATIONS

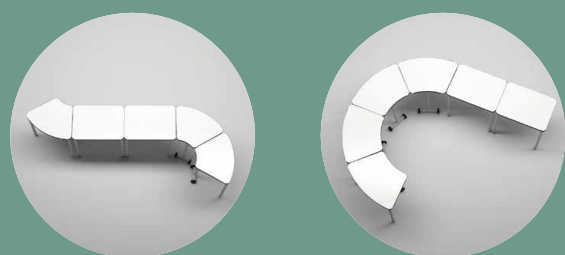

# ARROW

Ref. 2329IN

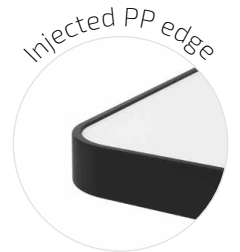

## SIZE

(+info P. 193)

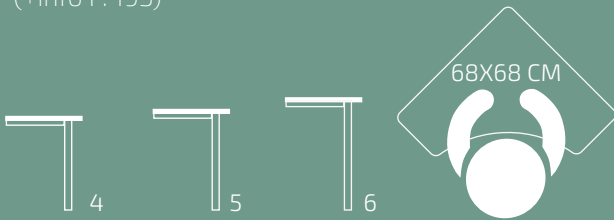

## COMBINATIONS

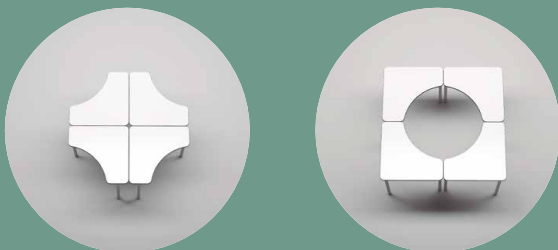

## DISTRIBUTION

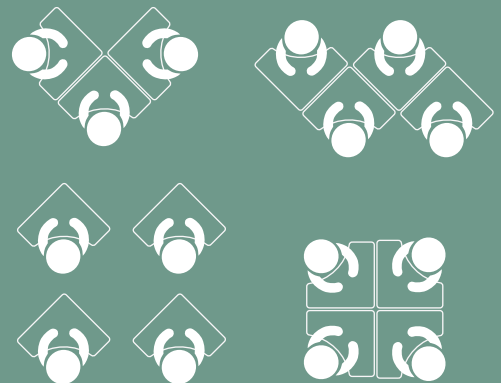



# HEXA

Ref. 2336IN

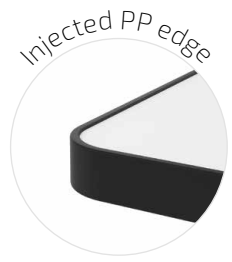

## SIZE

(+info P. 193)

72X50 CM



4



5



6

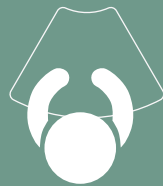

## COMBINATIONS

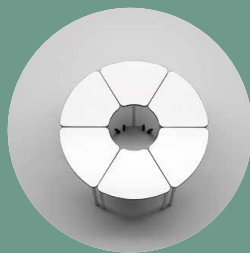

## DISTRIBUTION



Ø 150 cm



# OCTA

Ref. 2335IN



## SIZE

(+info P. 193)



## COMBINATIONS

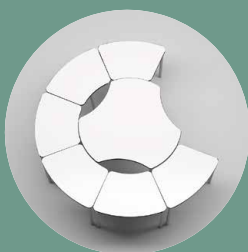

## DISTRIBUTION



Ø 222 cm





# YANG

Ref. 2345RC (1-3)

Ref. 2345R (4-6)



1-3



4-6

ABS edge



## SIZE

(+info P. 193)



## DISTRIBUTION

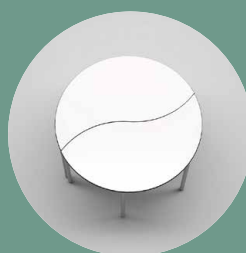
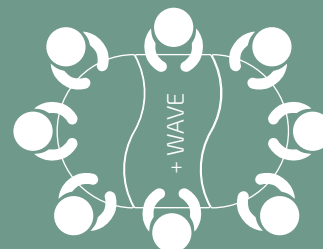

# WAVE

Ref. 2344RC (1-3)

Ref. 2344R (4-6)



1-3



4-6

ABS edge



## SIZE

(+info P. 193)

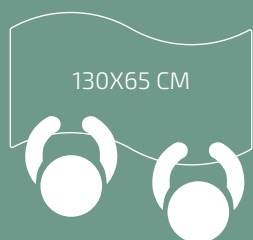

## DISTRIBUTION

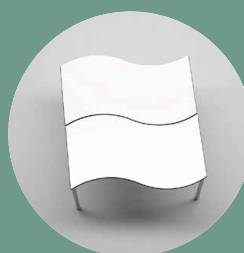
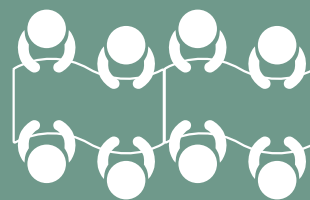
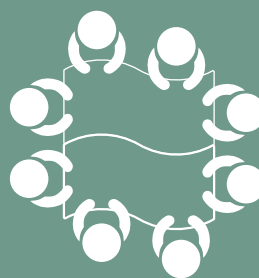



# TRISIX

Ref. 2346RCIN (1-3)  
Ref. 2346IN (4-6)



1-3



4-6



## SIZE

(+info P. 193)



## DISTRIBUTION

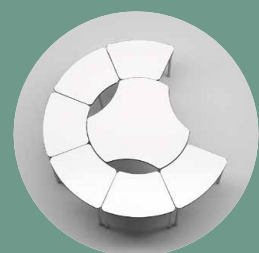
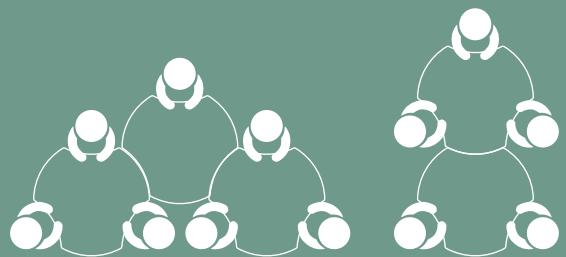

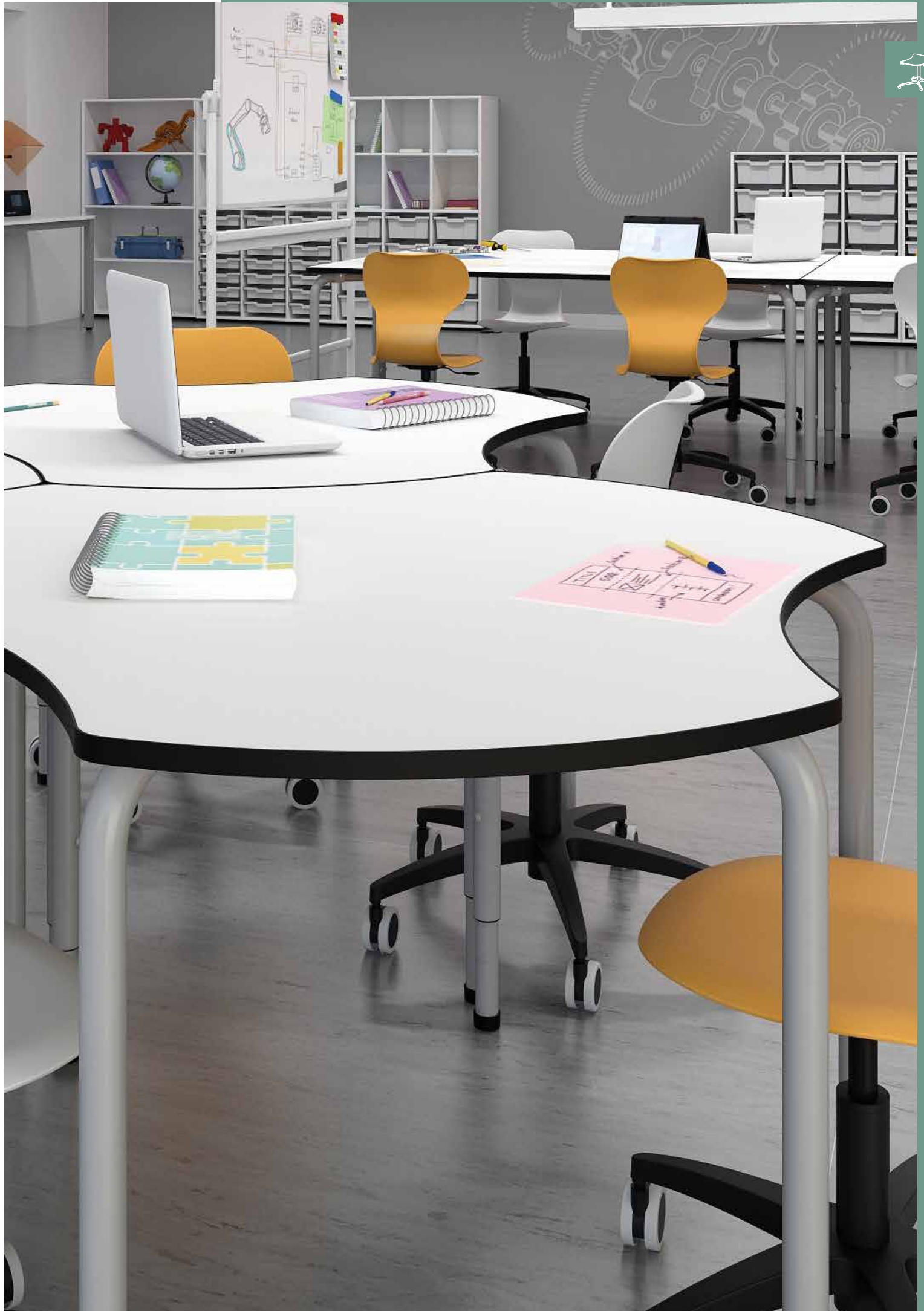



# RECTANGLE

Ref. 2352-3 (1-3)  
Ref. 2352-6 (4-6)



1-3



4-6

ABS edge



## SIZE

(+info P. 193)

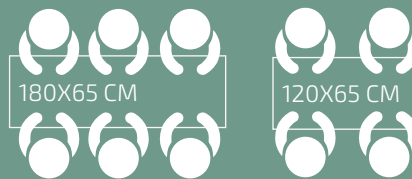

## SIZE

(+info P. 189)

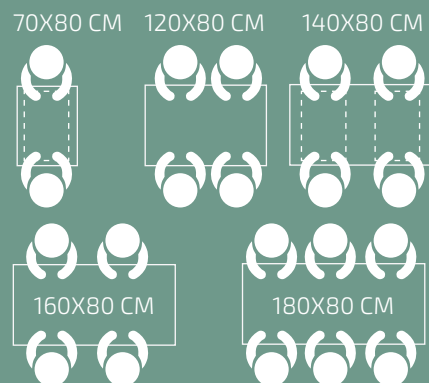

# RECTANGLE PLUS

Ref. 2353-8



ABS edge



## SIZE

(+info P. 193)



120X65 CM



180X65 CM

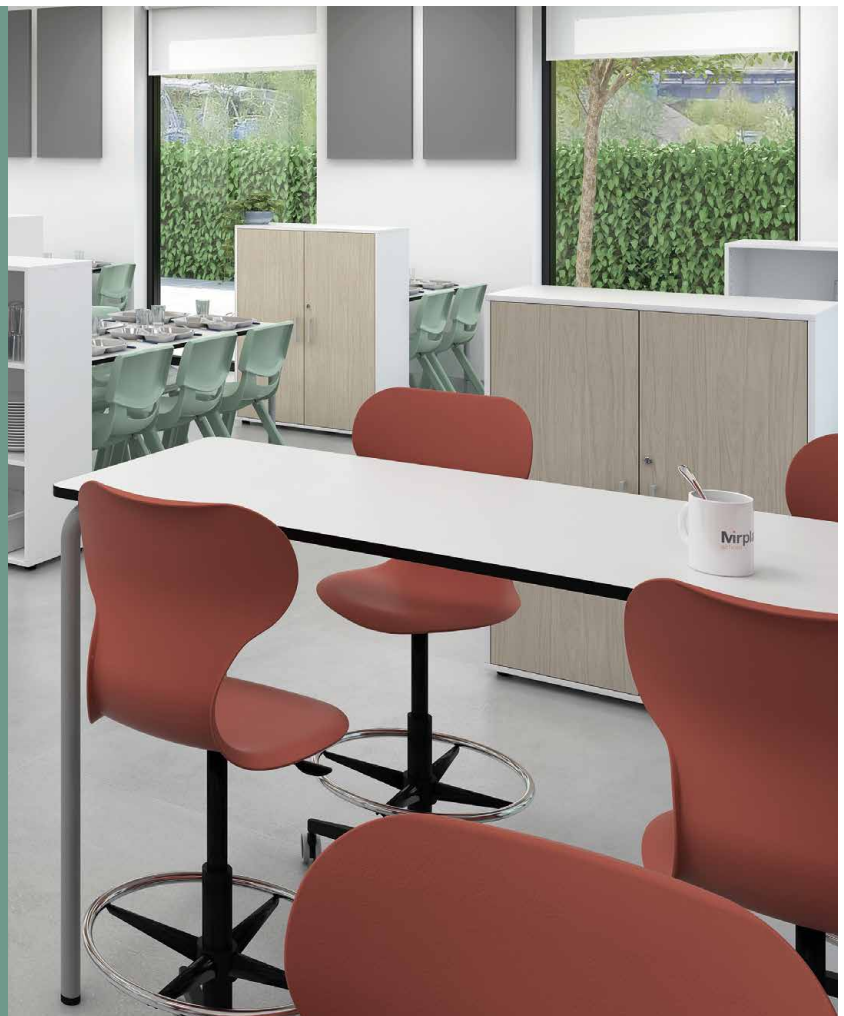



# RECTANGLE TEACHER

Ref. 2355D



## SIZE

(+info P. 193)

120X65 CM





# NAXEL

Ref. 620

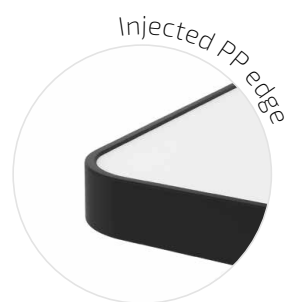

## SIZE

(+info P. 193)



4



5



6

70X50 CM







# SPACE DESIGN

Ref. 261



OPTIONS



## SIZE

(+info P. 193)

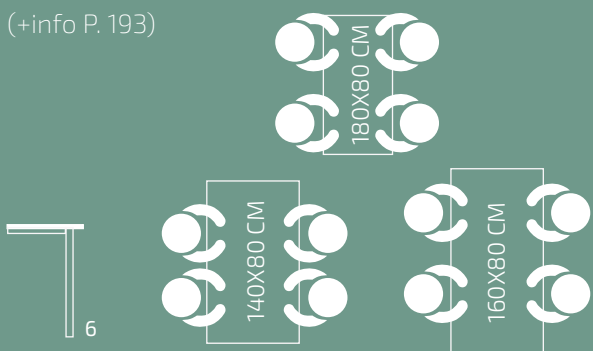

## DETAILS



## OPTIONS





# SPACE PLUS

Ref. 260



## SIZE

(+info P. 193)



## DETAILS







# ALULOOP

Ref. 2048R

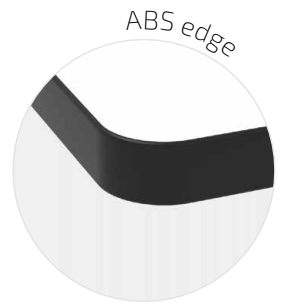

## SIZE

(+info P. 193)

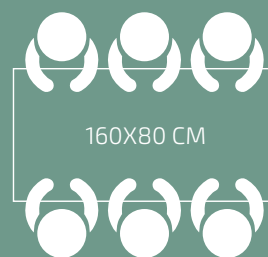
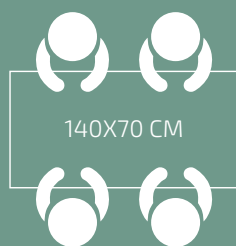
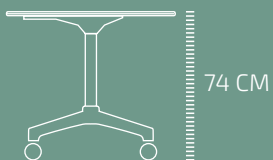

# MINIFLOOP

Ref. 2261DNR



ABS edge

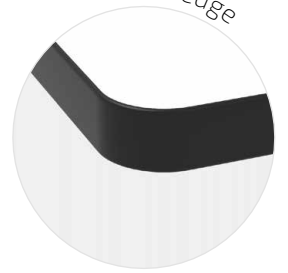

## SIZE

(+info P. 193)



1



2



3



4

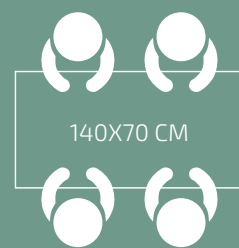

140X70 CM



# LOUISE

Ref. 2354



H 47 CM



H 70 CM



360°

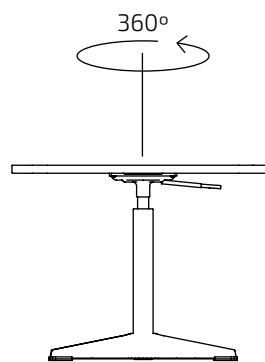

## SIZE

(+info P. 193)

66 CM

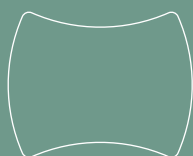

52 CM

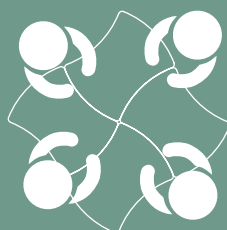

## DETAILS





# RONY

Ref. 2221 - 2220



## SIZE

(+info P. 193)



## OPTIONS

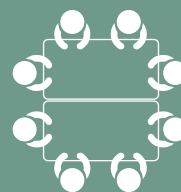
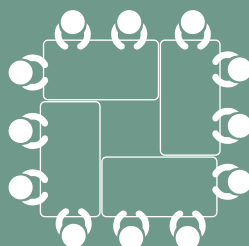
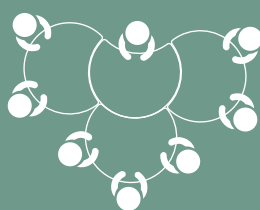

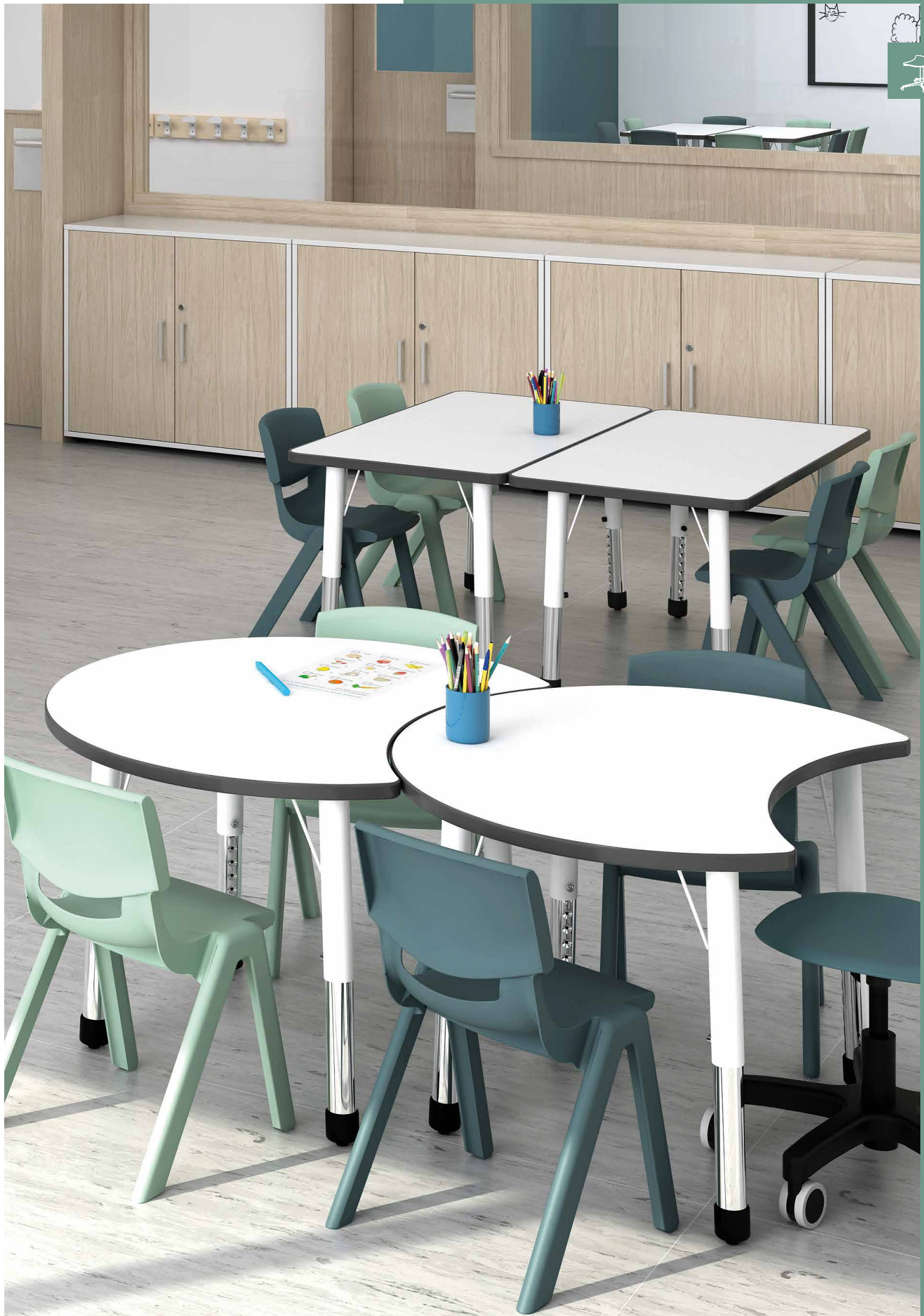



# TEO

Ref. 2368



## SIZE

(+info P. 193)



## DETAILS



# Acoustic

Making the classroom experience better. Acoustic panels and dividers absorb sound, reduce reverberation and improve intelligibility, well-being, concentration and speech performance in classrooms.

---

Améliorer l'expérience en classe. Les panneaux et cloisons acoustiques absorbent le son, réduisent la réverbération et améliorent l'intelligibilité, le bien-être, la concentration et les performances de la parole dans les salles de classe.





# ARA

Ref. 2106-625

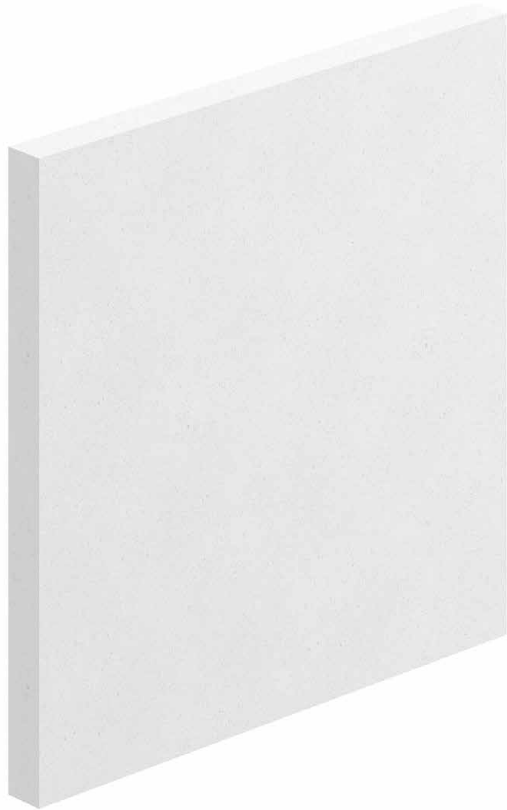

## SIZE

62,5 X 62,5 CM

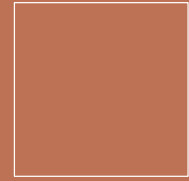

## DETAILS

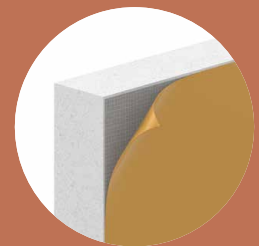

# LEDA

Ref. 2106-625



## SIZE

62,5 X 62,5 CM

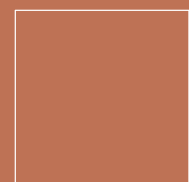

## DETAILS

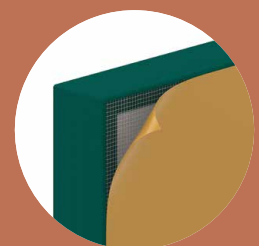

## SIZE

62,5 X 120 CM

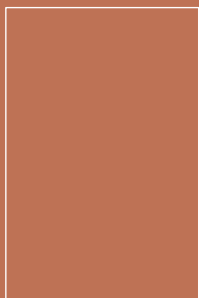

## OPTIONS

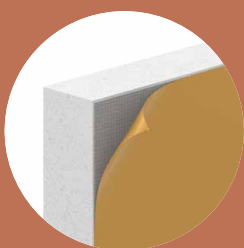

## CERES

Ref. 2106-1200



## SIZE

62,5 X 120 CM

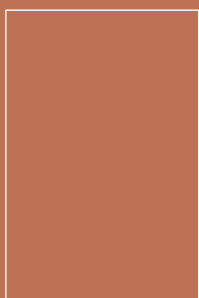

## OPTIONS

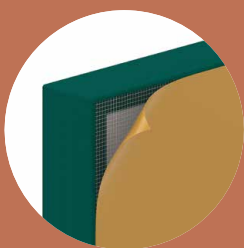

## MENSA

Ref. 2106-1200





# SAMOS

Ref. 2104

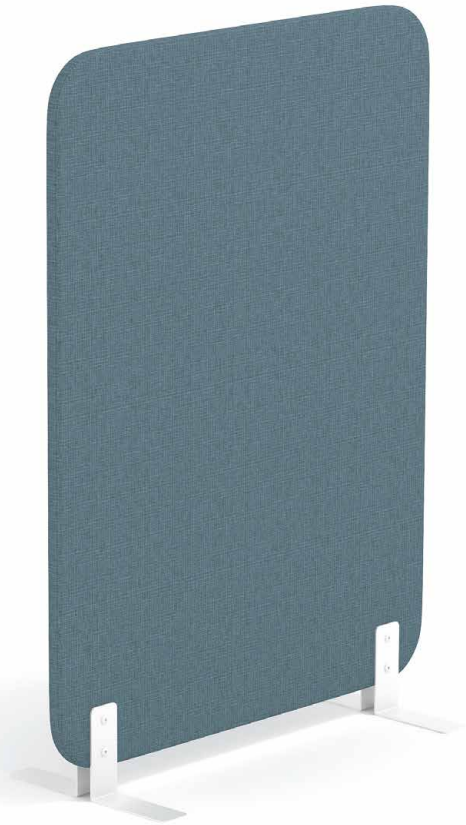
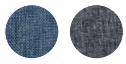

## SIZE

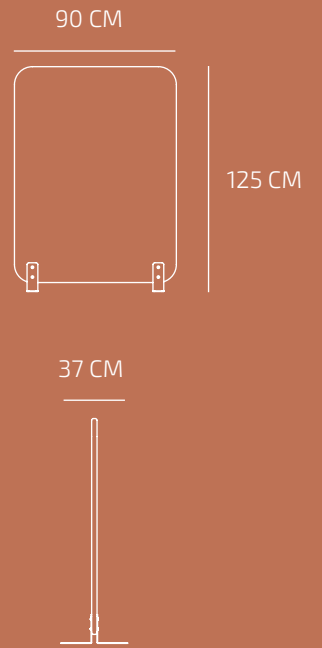

# ELEA

Ref. 2105



## SIZE

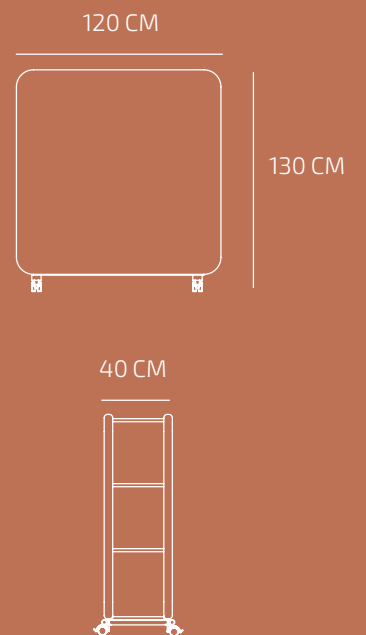





# AURE S

Frame



Interior panel



Wall panel exterior



INSIDE FURNITURE INCLUDED

## SIZE

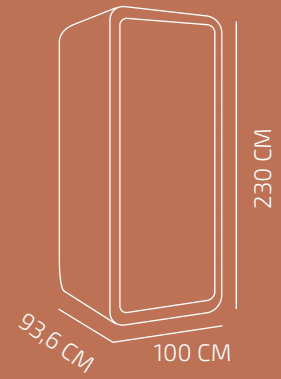

# AURE M

Frame



Interior panel



Wall panel exterior



INSIDE FURNITURE INCLUDED

## SIZE

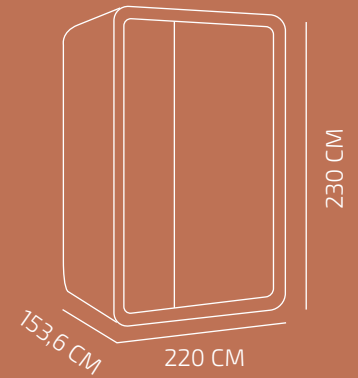

# AURE L

Frame



Interior panel



Wall panel exterior



INSIDE FURNITURE INCLUDED

## SIZE

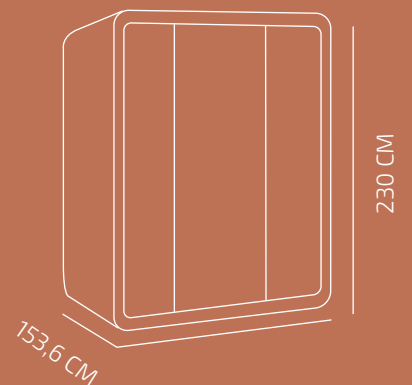



Mirplay

# Cabinets

Everything in its place.

Each educational space and classroom have their specific requirements for learning material and distribution. Cabinets are a key element designed to facilitate the different dynamics and the order that each classroom needs.

---

Chaque chose à sa place.

Chaque espace éducatif et salle de classe a ses exigences spécifiques en matière de matériel d'apprentissage et de distribution. Les armoires sont un élément clé conçu pour faciliter les différentes dynamiques et l'ordre dont chaque classe a besoin.







H 80cm



**MARIE**  
Ref. 732-601



**HEDY**  
Ref. 532-501



**ADA**  
Ref. 532-502



**JANE**  
Ref. 632-504

H 120cm



**IRENE**  
Ref. 533-501



**EMMY**  
Ref. 533-502



**ANNIE**  
Ref. 633-507



**SOPHIE**  
Ref. 633-501

H 160cm



**MILEVA**  
Ref. 534-501



**FLORA**  
Ref. 534-508



**INGE**  
Ref. 534-509



**ELSA**  
Ref. 634-508

H 200cm



**EMILIE**  
Ref. 535-501



**MAUD**  
Ref. 535-508



**ROSIE**  
Ref. 535-521



**MERIT**

Ref. 632-507



**GRACE**

Ref. 632-501



**ALICE**

Ref. 634-510



**DAN**

Ref. 551

COLOURS

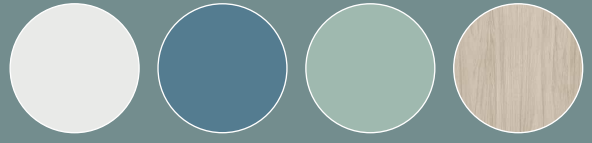

DETAILS



OPTIONS





# MARIE

Ref. 732-601

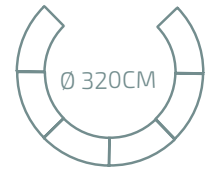

## SIZE

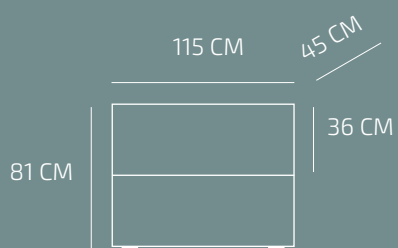

## OPTIONS



## COMBINATIONS



# HEDY

Ref. 532-501



# ADA

Ref. 532-501



## SIZE

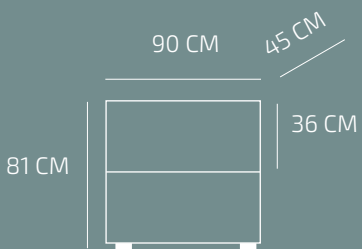

## OPTIONS



## DETAILS



# JANE

Ref. 632-504



## SIZE

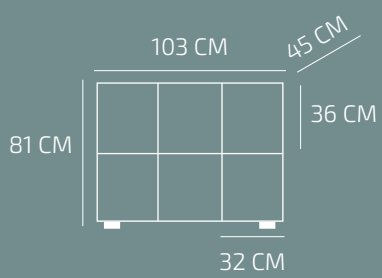

## OPTIONS



# MERIT

Ref. 632-507

Ref. 632-508



 x 9



 x 12



## SIZE

Ref. 632-507

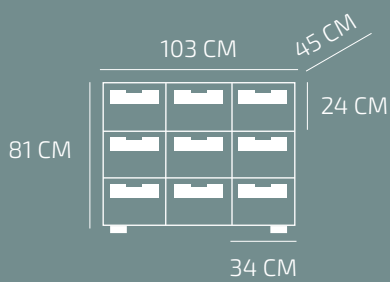

Ref. 632-508

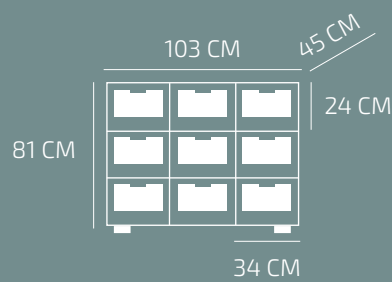

## OPTIONS





# GRACE

Ref. 632-501

Ref. 632-503



 x 21



 x 12



## SIZE

Ref. 632-501

Ref. 632-503

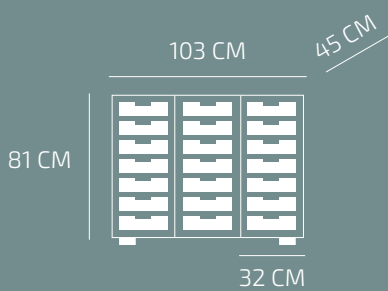

## OPTIONS







# IRENE

Ref. 533-501



# EMMY

Ref. 533-502



## SIZE

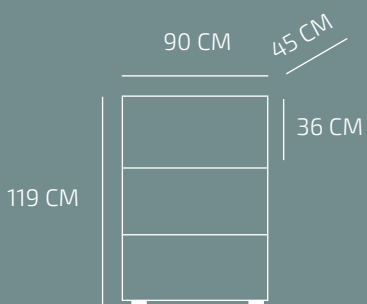

## OPTIONS



## DETAILS





# ANNIE

Ref. 633-507

Ref. 633-509



 x15



 x15



## SIZE

Ref. 633-507

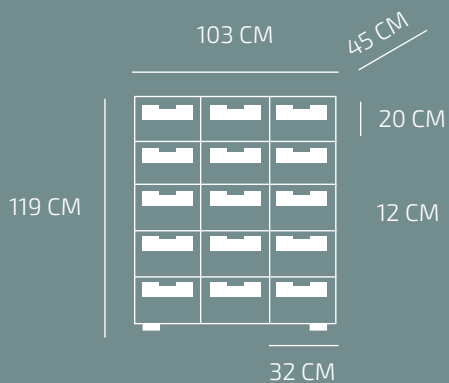

Ref. 633-509

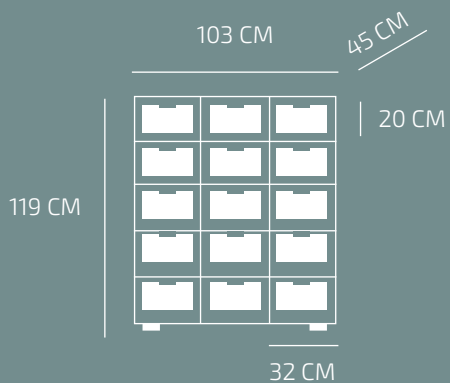

# SOPHIE

Ref. 633-501

Ref. 633-503



 x33



 x18



## SIZE

Ref. 633-501

Ref. 633-503

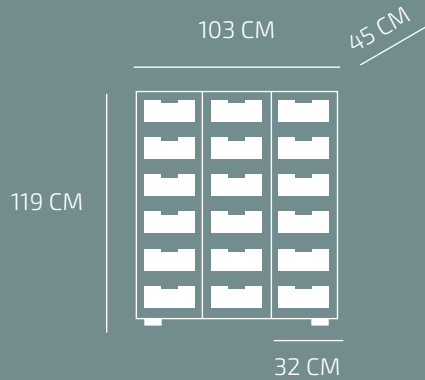
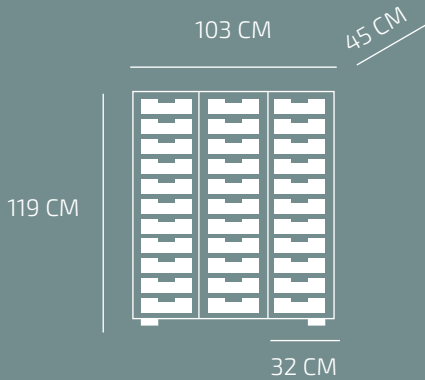



## MILEVA

Ref. 534-501



## FLORA

Ref. 534-508





# INGE

Ref. 534-509



## SIZE

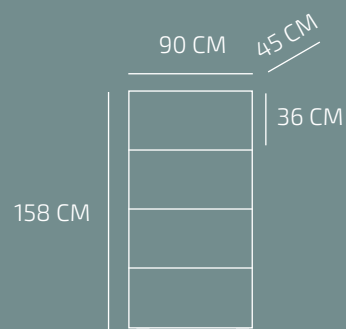

## OPTIONS





# ELSA

Ref. 634-508



## SIZE

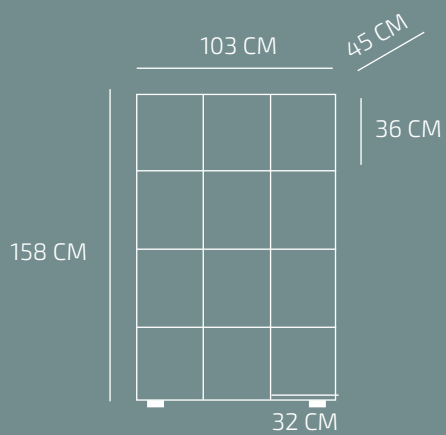

# ALICE

Ref. 634-510

Ref. 634-512



 x 21



 x 12



## SIZE

Ref. 634-510

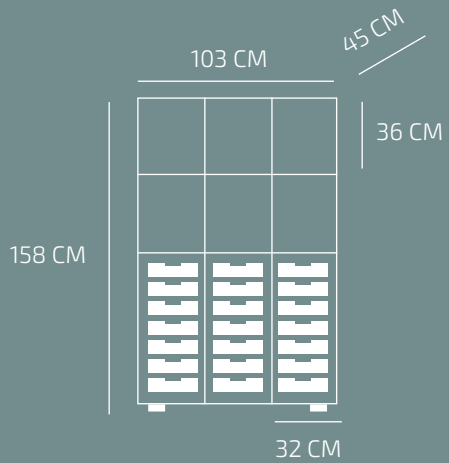

Ref. 634-512

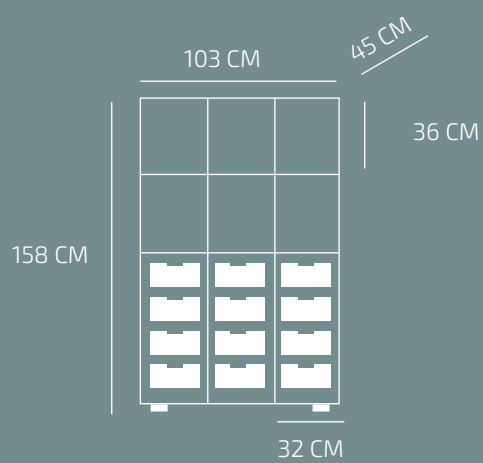



## EMILIE

Ref. 535-501



## MAUD

Ref. 535-508



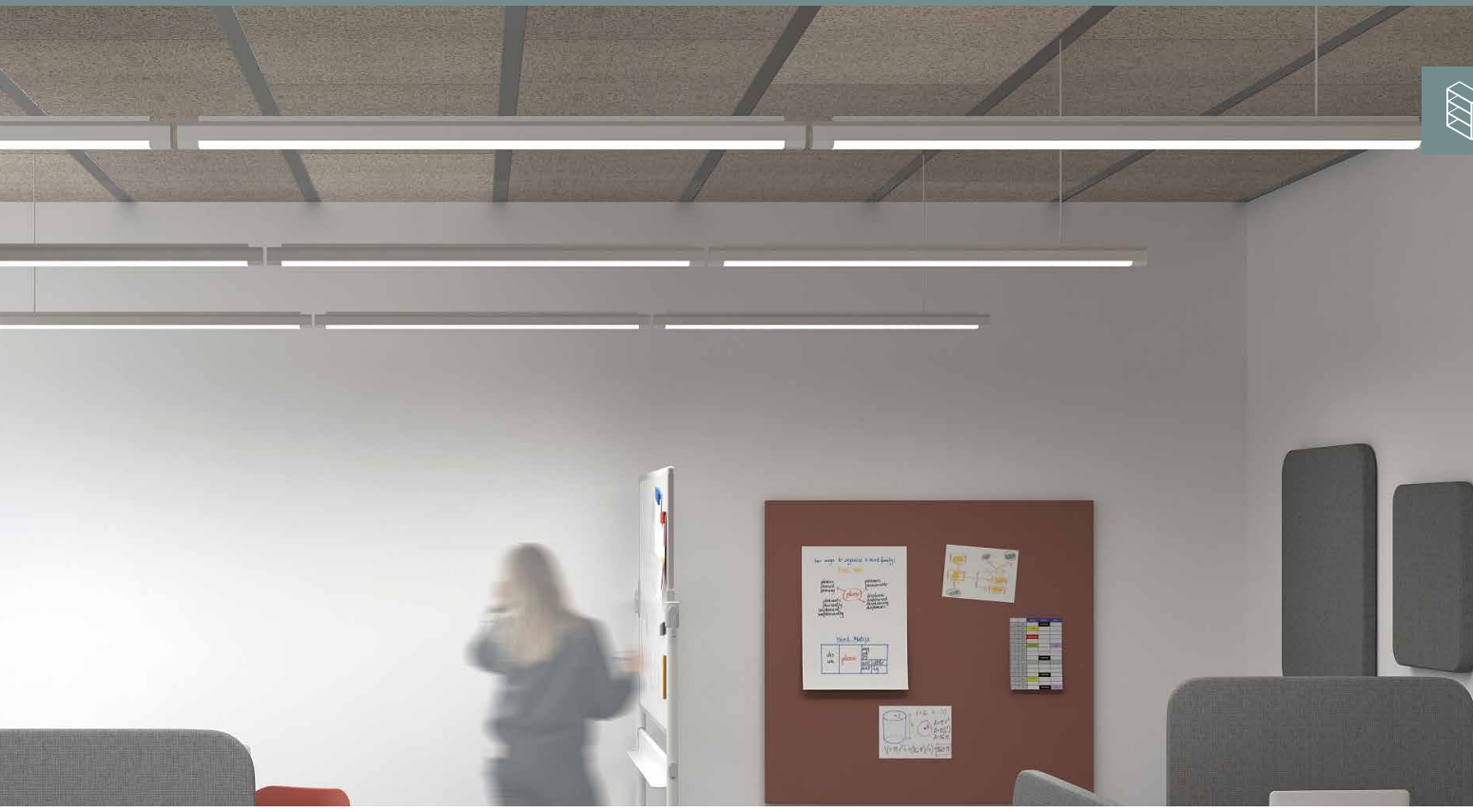

# ROSIE

Ref. 535-521



## SIZE

90 CM

45 CM

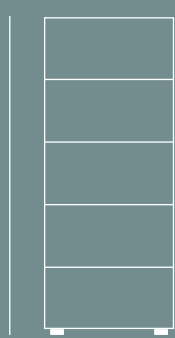

36 CM

196 CM

## OPTIONS





# DAN

Ref. 551



## SIZE

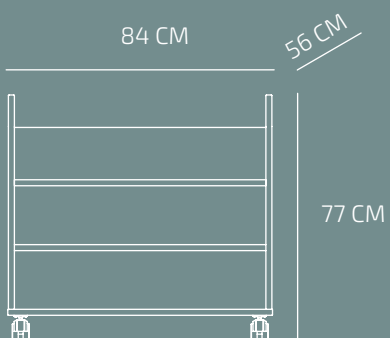

## DETAILS





# Complements

For a smoother experience.  
Support tools designed to facilitate  
collaborative learning dynamics and a fluid  
and orderly cohabitation in the classroom.

---

Pour une expérience plus fluide.  
Des outils de soutien conçus pour faciliter une  
dynamique d'apprentissage collaborative et  
une cohabitation fluide et ordonnée en classe.



CONNECTIONS

CONCEPTS

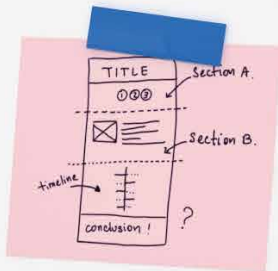

NOVEMBER						
Mo	Tu	We	Th	Fr	Sa	Su
	1	2	3	4	5	6
7	8	9	10	11	12	13
14	15	16	17	18	19	20
21	22	23	24	25	26	27
28	29	30				

MARCH						
Mo	Tu	We	Th	Fr	Sa	Su
	1	2	3	4	5	
6	7	8	9	10	11	12
13	14	15	16	17	18	19
20	21	22	23	24	25	26
27	28	29	30	31		

KEY LEARNINGS

RELATE TO WORK

CONCLUSIONS

CONCRETE PRACTICE

→ Active Participation  
→ Collaborative Interdependence





## SIZE

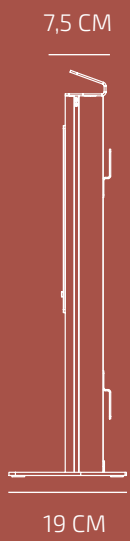
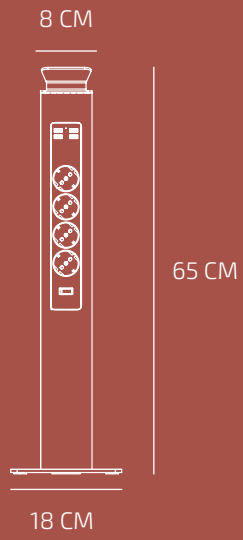

## DETAILS



## ODON



SIZE

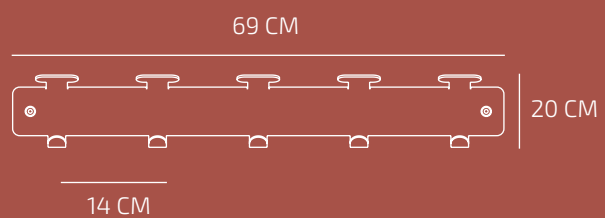

## MARCUS

Ref. 7028

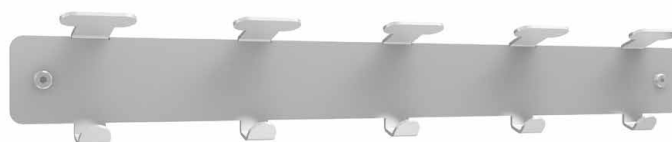

SIZE

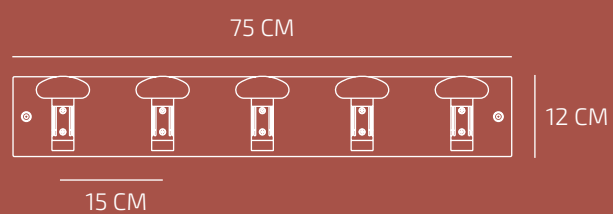

## PEGGY

Ref. 751





# LILY

Ref.4001



## SIZE

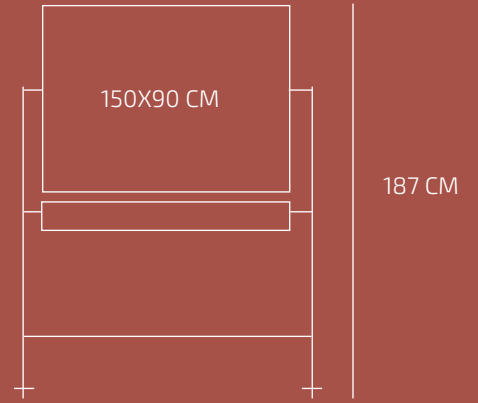

## DETAILS



# MINI LILY

Ref. 4002



Ref. 7029



## SIZE

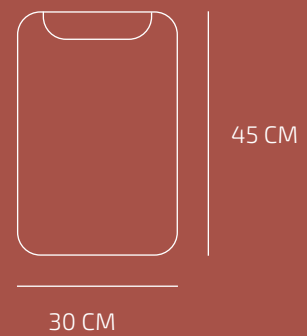



# Classroom design service

[mirplayschool.com](http://mirplayschool.com)

The team in Mirplay School helps you adapt your centre's learning spaces to the new educational dynamics taking place in it. Creating and optimising different spaces in a classroom, improving its acoustics and facilitating the orderly movement of students can be very easy.

With versatile furniture that is easy to move and store, comfortable and capable of coping with daily use, a wide range of possibilities opens up.

---

L'équipe de Mirplay School vous aide à adapter les espaces d'apprentissage de votre centre aux nouvelles dynamiques pédagogiques qui s'y déroulent. Créer et optimiser différents espaces dans une salle de classe, améliorer son acoustique et faciliter le déplacement ordonné des élèves peut être très simple.

Avec des meubles polyvalents, faciles à déplacer et à ranger, confortables et capables de faire face à un usage quotidien, un large éventail de possibilités s'ouvre.

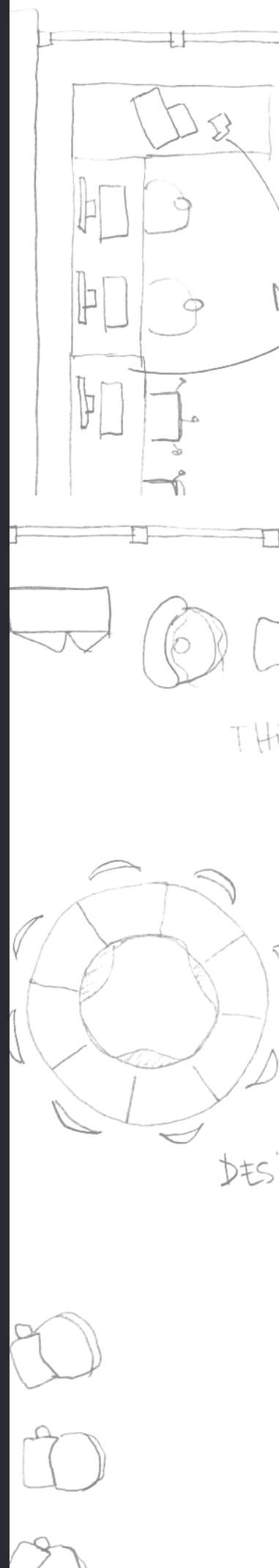

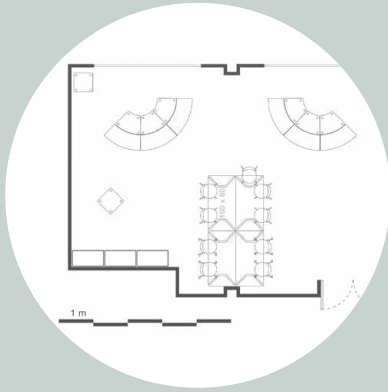

## FLOOR LAYOUT VUE EN PLAN

We offer a proposal for the distribution of your space in a plan view, simple and easy to implement.

Nous vous proposons une distribution de votre espace en vue de dessus, simple et facile à mettre en œuvre.



## 3D VIEWS OF YOUR SPACE VUES 3D DE VOTRE ESPACE

Do you want to visualize how it will look like? You just have to tell us what the space is like, what you want to achieve and we will make you a proposal in 3D image.

Voulez-vous visualiser à quoi cela ressemblera? Il vous suffit de nous dire comment est l'espace, ce que vous souhaitez réaliser et nous vous ferons une proposition en image 3D.

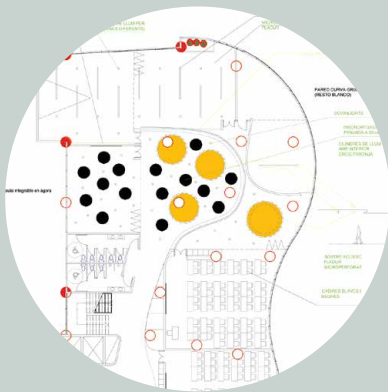

## ARCHITECTURAL DRAFT PROJET DE DÉCORATION

Our team of architects projects and adapts the space so that it supports and stimulates the activities that will take place in it.

Notre équipe d'architectes projette et adapte l'espace pour qu'il soutienne et stimule les activités qui s'y dérouleront.



## FURNISHING PROJECT PROYECTO DE DECORACIÓN

We guide you in interior design decisions to create a comprehensive decoration proposal.

Nous vous guidons dans les décisions d'aménagement intérieur pour créer une proposition de décoration globale.

JON  
1045



p. 94

MIA BASIC  
1028



p. 98

MIA CANTILEVER  
1027



p. 99

MIA CASTORS  
1029



p. 100

MIA MINI LIFT  
169



p. 101

MIA LIFT  
1035



p. 102

MIA BIG LIFT  
1039



p. 103

MIA STOOL  
1030



p. 104

MIA STORE  
1038



p. 105

MIA TABLE  
1036



p. 106

ZTOOL  
1020



p. 108

ZTOOL TROLLEY  
1037



p. 108

LUCA  
167-1/2/3/4/5/6



p. 111

ZOE  
1044



p. 111

CHLOE



p. 114

CHARLOTTE  
1041



p. 115

ANGLE  
12001



p. 116

CUBE  
12002



p. 116

TUBE  
12003



p. 117

COMPLETE SOFA  
12005



p. 117

MOVE  
1608



p. 118

MINI MOVE  
1609



p. 119

MOON  
2362



p. 123

SQUARE  
2341IN



p. 124

ARROW  
2329IN



p. 125

HEXA  
2336IN



p. 126

OCTA  
2335IN



p. 127

YANG  
2345R



p. 128

WAVE  
2344R



p. 129

TRISIX  
2346IN



p. 130

RECTANGLE  
2352



p. 132

RECTANGLE PLUS  
2353



p. 133

RECTANGLE TEACHER  
2355D



p. 135

NAXEL  
620



p. 136

SPACE DESIGN  
261



p. 139

SPACE PLUS  
260



p. 140

ALUFLOOP  
2048R



p. 142

MINIFLOOP  
226DNR



p. 143

LOUISE  
2354



p. 145

RONY  
2221



p. 146

RONY  
2220



p.146

TEO  
2368



p. 149

ARA  
2106-625

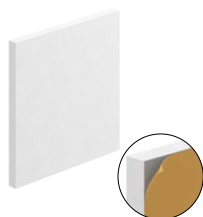

p. 152

LEDA  
2106-625

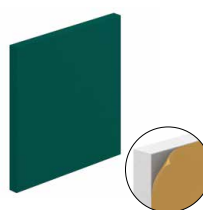

p. 152

CERES  
2106-1200



p. 153

SAMOS  
2104



p. 154

ELEA  
2105



p. 154

AURE S



p. 156

AURE M



p. 156

AURE L



p. 156

**MARIE**  
732-601



p. 162

**HEDY**  
532-501



p. 163

**ADA**  
532-502



p. 163

**JANE**  
632-504



p. 164

**MERIT**  
632-507



p. 165

**MERIT**  
632-508



p. 165

**GRACE**  
632-501



p. 166

**GRACE**  
632-503



p. 166

**IRENE**  
533-501



p. 169

**EMMY**  
533-502



p. 169

**ANNIE**  
633-507



p. 170

**ANNIE**  
633-509



p. 170

**SOPHIE**  
633-501



p. 171

**SOPHIE**  
633-503



p. 171

**MILEVA**  
534-501



p. 172

**FLORA**  
534-508



p. 172

**INGE**  
534-509



p. 173

**ELSA**  
634-508



p. 174

**ALICE**  
634-510

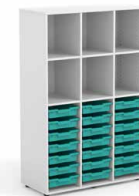

p. 175

**ALICE**  
634-512



p. 175

**EMILIE**  
535-501



p. 176

**MAUD**  
535-508



p. 176

**ROSIE**  
535-521



p. 177

**DAN**  
551



p. 178

**ODON**



p. 182

**MARCUS**  
7028



p. 183

**PEGGY**  
751



p. 183

**LILY**  
4001



p. 184

**MINI LILY**  
4002



p. 184

**MINI LILY HOOK**  
7029



p. 184



OVERVIEW VUE D'ENSEMBLE

# Size

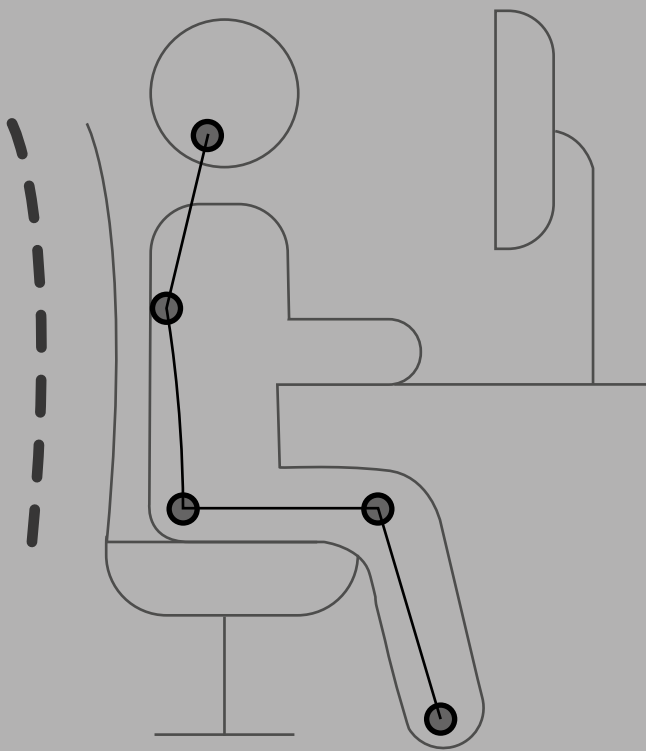

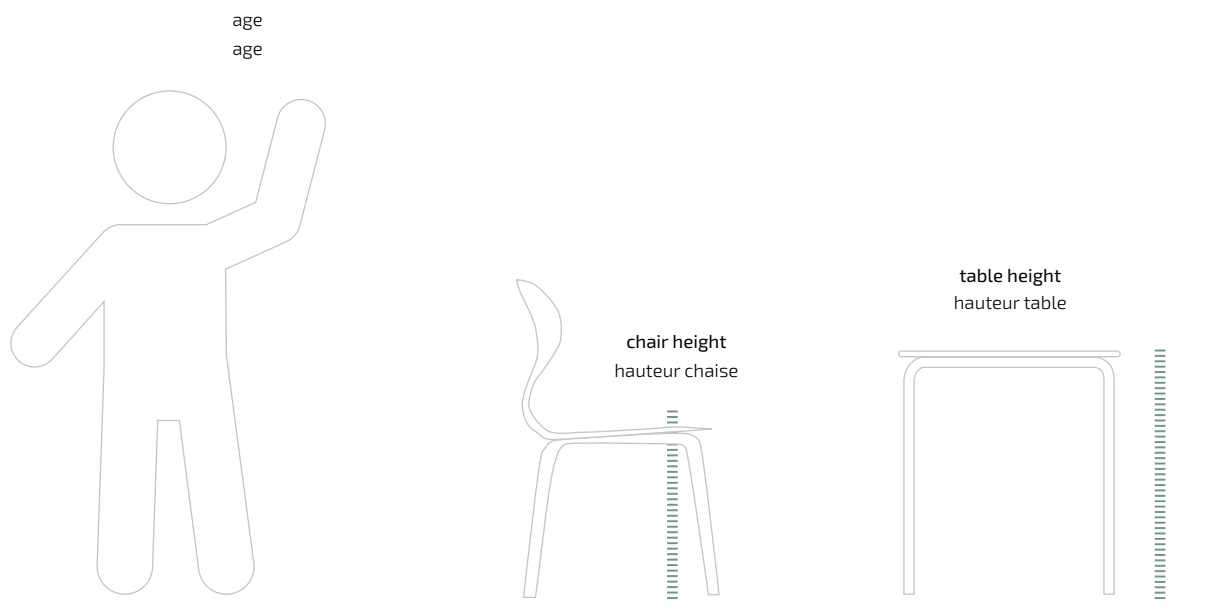

SIZE TAILLE	AGE AGE	CHAIR HEIGHT HAUTEUR CHAISE	TABLE HEIGHT HAUTEUR TABLE
<b>0</b>	1-2	21 cm	40 cm
<b>1</b>	2-3	26 cm	46 cm
<b>2</b>	3-4	30 cm	52 cm
<b>3</b>	4-6	34 cm	59 cm
<b>4</b>	6-8	38 cm	65 cm
<b>5</b>	8-10	42 cm	70 cm
<b>6</b>	+12	46 cm	77 cm
<b>8*</b>	+8	80 cm	100 cm

Size according to European regulation UNE EN 1729-1: 07 / UNE EN 1729-2: 07.  
 Taille selon la norme européenne UNE EN 1729-1: 07 / UNE EN 1729-2: 07.

\*Equivalence UNE-EN 1729-1 size 5 dimensions for tables to work standing up.

\*Equivalence UNE-EN 1729-1 aux dimensions 5 pour les tables de travail debout.

Our products are designed and manufactured according to the corresponding implementation regulations:

Chairs and tables for educational institutions.

UNE EN 1729-1: 07 / UNE EN 1729-2: 07.

Dimensions, safety requirements and test methods.

According to UNE 56843:01 furniture specifications.

UNE-EN 71-3:94 - Migration of metallic elements.

Mirplay certifies its products in European laboratories SGS.

---

Nos produits sont conçus et fabriqués selon les normes d'application correspondantes. Relation des normes applicables:

Chaises et tables pour centres d'enseignement.

UNE EN 1729-1: 07 / UNE EN 1729-2: 07.

Dimensions, exigences de sécurité et méthodes d'essais.

Selons spécifications UNE 56.843: 01 Mobilier.

UNE - EN 71-3: 94 - Migración d'éléments métalliques.

Mirplay certifie ses produits aux laboratoires de référence internationale et SGS.



\* Minimum of 60% post-consumer recycled plastic

\* Minimum de 60% de plastique recyclé post-consommation



AEN-COC-000451

The catalogue's images have not a contractual value. They are illustrative and they cannot correspond exactly with the product. The images shown in this catalogue are property of Mobles Mir i Equipaments, its reproduction, distribution, public communication and transformation are forbidden without authorization.

Les images de ce catalogue n'ont pas de valeur contractuelle. Ils sont illustratifs et peuvent ne pas correspondre exactement au produit. Les images qui apparaissent dans ce catalogue sont de la propriété de Mobles Mir i Equipaments, toute reproduction, diffusion, communication publique et transformation sont interdites sans autorisation.



Mirplay

# Mirplay<sup>®</sup>

school



[mirplayschool.com](http://mirplayschool.com)

## HEADQUARTERS

BP-4313 - Punt Km 28,7  
08279 Avinyó · BCN · SPAIN

+34 938 124 452  
[info@mirplayschool.com](mailto:info@mirplayschool.com)

## MIRPLAY MÉXICO

[mexico@mirplay.com](mailto:mexico@mirplay.com)

---

## MIRPLAY UK

[uk@mirplay.com](mailto:uk@mirplay.com)

---

## MIRPLAY ASIA

[asia@mirplay.com](mailto:asia@mirplay.com)